



2007 *M.T.H. RailKing[®]*
Train Sets & Accessories

THE HIGHEST QUALITY TRAIN SETS YOU CAN BUY

WELCOME TO MODEL RAILROADING THE WORLD'S GREATEST HOBBY!

Why do we love trains? Perhaps because, outside of an ocean liner, they're the biggest moving objects on earth. Perhaps because their whistles and horns are loud and wonderful, and the ground shakes when they go by. Perhaps because they carry the mystery of faraway places.

We think model railroading is the World's Greatest Hobby because it recreates the sights and sounds and experiences that make real trains so dramatic and exciting - and because there are so many ways to enjoy model railroading. Some hobbyists collect old toy trains. Others operate their model layouts just like a real railroad. Some folks model a specific period in history or a specific railroad. Still other hobbyists specialize in building structures, making scenery, or electrical wiring. And for most of these men and women, what became a lifelong source of pleasure began with a train set they received as a holiday or birthday present. We hope you enjoy this catalog and that it inspires you to give someone you care about (or maybe yourself) a present that will be a lot of fun today - and could turn into a lifelong hobby.

WHO IS M.T.H.?

M.T.H. Electric Trains is the realization of a boyhood dream. In 1980, college student Mike Wolf, already an eight-year veteran of the model train industry, opened a mail order train business in a spare bedroom of his parents' home. Armed with a separate phone line and a fancy new device called a FAX machine, Mike processed and shipped orders, worked train shows on weekends, and worked for Williams Reproductions, a fledgling model railroad manufacturer.

Three years later, Mike's Train House, as the business was called then, made the leap into manufacturing by offering reproductions of tinplate



metal trains popular in the 1920s and '30s. Sheet-metal parts were stamped in Minnesota, shipped to Maryland where they were painted by a high-school friend of Mike's in his parents' garage, and assembled in the Wolf family's basement.

Mike's experience and expertise in manufacturing toy trains led to projects with Lionel® and other model railroad firms, and eventually he began to devote himself to manufacturing full time. In 1993, M.T.H. Electric Trains introduced its own O gauge product line with a scale-detailed diesel, and followed that up with dozens of realistic diesel, electric, and steam locomotives and cars.

RAILKING® SETS FOR BEGINNERS

In 1995 the first RailKing O Gauge products were introduced. Aimed at beginners and at hobbyists who prefer more traditional-sized toy trains, lower-cost, less-detailed RailKing models offer the same outstanding quality as more expensive scale-sized M.T.H. Premier engines and rolling stock. Mike Wolf has always recognized that a child's first train set represents the best hope for perpetuating our hobby, and RailKing train sets represent our commitment to making your introduction to model railroading a great experience.

In over a quarter-century of operation, Mike's Train House and M.T.H. Electric Trains have cataloged nearly 10,000 separate items. While much of our product line is made for experienced hobbyists, we also believe we make the finest entry-level O gauge train sets you can buy - because in the long run, train set customers are the future of our company. "Skimping on train set value is akin," Mike is fond of saying, "to slamming the door on a customer. By making that first experience one of quality, value, and fun, I believe we open the door to creating a model railroader for life."

WWW.MTHTRAINS.COM

M.T.H. TRAINS ARE MORE FUN

M.T.H. trains are more fun because they portray the sights and sounds that make real trains dramatic and exciting.

GREAT SMOKE

Our steam engines feature fan-driven ProtoSmoke™, the most powerful smoke system in the hobby.



SPEED CONTROL

Many toy trains have two speeds: fast and faster. Most M.T.H. locomotives feature Proto-Sound® 2.0, our unique sound and control system that allows our engines to throttle down to a slow crawl, highball down the main line, or maintain any speed in between. The Proto-Speed Control™ built into Proto-Sound 2.0 acts like the cruise control on a car, keeping your train moving at the speed you select, regardless of hills and curves.

RailKing train sets represent our commitment to making your introduction to model railroading a great experience.



N Gauge



HO Gauge



O Gauge



VIVID ENGINE SOUNDS

Proto-Sound features digital recordings with CD-quality playback: the wail of a diesel horn; the melody of an authentic steam whistle; the bell alerting passengers to your arrival or departure; and diesel roar or steam chuff that vary automatically depending on how hard your engine is working.

STATION SOUNDS

Proto-Sound passenger engines offer Passenger Station Proto-Effects™, a complete arrival and departure sequence that you can activate from your transformer. Freight engines include Freight Yard Proto-Effects, a symphony of freight terminal sounds.

SYNCHRONIZED CHUFF AND PUFF

Like a real steam engine, M.T.H. steamers feature puffs of smoke and steam chuff sounds synchronized with the drive wheels. Better than any other toy train, an M.T.H. locomotive portrays the drama of a steam engine s-l-o-w-l-y chuffing and puffing as it pulls out of a station and gets up to speed.

REMOTE UNCOUPLING

Proto-Sound steam and diesel engines offer remote uncoupling anywhere on your layout, accompanied by the clank of the coupler opening and the hiss of air hoses parting.

O GAUGE IS MORE FUN!

Model trains come in a variety of sizes. Smaller sizes such as HO gauge and N gauge allow hobbyists to fit a lot of highly detailed railroad into less space. But we think O gauge - the traditional size for train sets for more than half a century - is the perfect size for a child's first electric train. Judging by the rising popularity of O gauge over the past two decades, it has become the perfect size for many adults as well. Standing about twice the size of HO trains, O gauge trains are more fun because:

They stay on the track: O gauge trains hold the track better at the high speeds that children often prefer, thanks in part to the larger flanges on O gauge wheels.

They're easy to handle: The larger size of O gauge trains makes them easier for children to handle than smaller-gauge trains - and much easier to place on the track. Large-size operating knuckle couplers make



O gauge trains easy to couple and uncouple, and more fun to play with.

They're impressive: Size and weight make an O gauge train a memorable toy. M.T.H. steam engines feature die-cast metal boilers and frames, M.T.H. diesels feature die-cast trucks, and all M.T.H. products have metal wheels and couplers. If you're looking for a toy

that will make a long-term impression on a child, it's hard to beat an O gauge train.

They do things: As seen on this page and elsewhere in this catalog, O gauge offers a variety of operating, animated cars and accessories that is unmatched by any other scale or gauge.

QUALITY AND VALUE COMPARE BEFORE YOU BUY



RAILKING READY-TO-RUN TRAIN SETS INCLUDE TRACK, TRANSFORMER, INTERACTIVE DVD WITH TRACK LAYOUT SOFTWARE AND OPERATOR'S MANUAL.

At M.T.H., we consider the ready-to-run train set our best opportunity to make a great impression on any newcomer to the wonderful world of model railroading. That's why we don't skimp on the quality and value you'll find in every RailKing® and Tinplate Traditions™ ready-to-run starter set. Compare our sets with those of our competitors and you'll see what makes an M.T.H. starter set the best way to begin your model railroading journey.

Every RailKing O Gauge ready-to-run set features RealTrax®, O Gauge's first and most complete line of snap-together track with built-in roadbed. Only RealTrax uses solid metal track rails instead of cheaper hollow rails that can bend if stepped on. See the complete RealTrax line beginning on page 38.

Every 2007 M.T.H. Train set* features a U.L. approved 100-watt or stronger transformer to ensure that your set has enough power now and when you expand it with extra cars, track and accessories.

* Except Trolley sets, which include a 40-watt transformer, and the Coors Silver Bullet set, which does not include track or transformer.



EVERY RAILKING PASSENGER CAR HAS A DETAILED, LIGHTED INTERIOR.



EVERY RAILKING LOCOMOTIVE FEATURES DURABLE METAL GEARS, WHEELS, AND AXLES



EVERY RAILKING CAR AND LOCOMOTIVE FEATURES DIE-CAST METAL TRUCKS AND COUPLERS.



SERVE 'EM UP WITH THIS **OPERATING MCDONALDS™** WITH SOUNDS, PAGE 46.



PATROL THE SKIES WITH A **FLYING HELICOPTER CAR**, PAGE 25.



DROP OFF FREIGHT WITH AN **OPERATING DUMP CAR**, SEE PAGE 14, 23, 27, OR 31.



USE THIS **OPERATING WATER TOWER** TO FILL UP YOUR TENDER; SEE PAGE 51.



USE REAL WATER TO PUT OUT THIS **SMOKING FIRE**; DETAILS ON PAGE 47.



WATCH THESE WORKERS MOVE THE FREIGHT AT THIS **ANIMATED TRANSFER DOCK**, PAGE 46.

The Highest Quality Train Sets You Can Buy



EVERY RAILKING LOCOMOTIVE AND TRAIN SET IS BUILT TO THE SAME QUALITY STANDARD AS OUR TOP-OF-THE-LINE PREMIER BIG BOY

READY-TO-RUN SET FEATURES

As explained on the previous pages and detailed below, M.T.H. train sets are loaded with features you won't find in smaller gauge trains or in other O gauge sets. On the next 33 pages, you'll find our full 2007 train set lineup. The following lists cover the general features found in each set. For a specific listing of each set's features, visit our Web site -at www.mthtrains.com.



SET CONTENTS

O Gauge RailKing and Tinplate Traditions™ Sets* (except trolleys) include:

- Locomotive
- 3-Car passenger or freight consist
- 31" x 51" 12-piece RealTrax® oval
- Lighted track Lock-On, with wires to connect to transformer
- UL-approved 100-watt Z-1000™ transformer
- RailWare interactive DVD with track layout software

* Coors Silver Bullet set does not include track or transformer

O Gauge RailKing Trolley Sets include:

- Lighted trolley with bump-reverse
- 31" 8-piece RealTrax® circle
- Lighted track lock-on, with wires to connect to transformer
- UL-approved 40-watt ZDC transformer
- RailWare interactive DVD with track layout software

Standard Gauge Tinplate Traditions Sets include:

- Locomotive
- 2-Car passenger consist
- 8-piece 42" circle of Standard Gauge track
- Lighted track Lock-On, with wires to connect to transformer
- UL-approved 100-watt Z-1000™ transformer

LOCOMOTIVE FEATURES

RailKing Steam Engines Feature:

- Die-cast metal boiler* and chassis
- Flywheel-equipped motor
- Synchronized puffing ProtoSmoke™
- Operating headlight
- All-metal wheels and gears
- Proto-Sound® 2.0 sound and control system featuring locomotive speed control and CD-quality digital sounds that include whistle, bell, steam chuff, Passenger or Freight Station Proto-Effects™, crew conversations, and atmospheric sounds.**
- Remotely controlled Proto-Coupler™ on tender

* Coors Silver Bullet Locomotive features ABS boiler

**Loco-Sound Engines Feature bell, whistle, and chuff sounds only

RailKing Diesel Engines Feature:

- Intricately detailed durable ABS body
- Metal frame
- Die-cast metal pilots and trucks
- Twin flywheel-equipped motors
- Operating ProtoSmoke™
- Operating headlight
- Operating backup light (RS-3, GP-9 diesels only)
- All-metal wheels and gears
- Proto-Sound® 2.0 sound and control system featuring locomotive speed control and CD-quality digital sounds that include horn, bell, diesel motor, Passenger or Freight Station Proto-Effects™, crew conversations, and atmospheric sounds.*
- 2 remotely controlled Proto-Couplers™

*Loco-Sound Engines Feature bell, horn, and diesel motor only

Tinplate Traditions Steam Engines Feature:

- Die-cast metal chassis
- Stamped metal boiler, cab, and tender
- Flywheel-equipped motor
- Synchronized puffing ProtoSmoke™
- Operating headlight
- All-metal wheels and gears
- Proto-Sound® 2.0 sound and control system featuring locomotive speed control and CD-quality digital sounds that include whistle, bell, steam chuff, Passenger or Freight Station Proto-Effects™, crew conversations, and atmospheric sounds.*
- Remotely controlled Latch-Type Proto-Coupler™ on tender (O Gauge engines only)

ROLLING STOCK FEATURES

RailKing Freight Cars Feature:

- Intricately detailed durable ABS body
- Die-cast metal trucks with smooth-rolling metal wheels and axles
- Die-cast metal operating knuckle couplers
- Opening doors on boxcars
- Lighted interiors on cabooses
- Colorful, attractive paint schemes

RailKing Passenger Cars Feature:

- Intricately detailed durable ABS body
- Interior seating and overhead lighting
- Die-cast metal trucks with smooth-rolling metal wheels and axles
- Die-cast metal operating knuckle couplers
- Colorful, attractive paint schemes

Tinplate Traditions Cars Feature:

- Stamped Steel Body
- Colorful baked enamel finish
- All-metal trucks with smooth-rolling metal wheels and axles
- Operating latch-type couplers
- Opening doors on reefers, boxcars, and cattle cars



SERVICE INFO

Our Service Page is your direct link to the M.T.H. Tech Support Team. Register your warranty, find a local service center or submit a product specific question here. You can even place a parts order through our secured server. It's easy and quick like it should be when you're looking for answers.



PRODUCT LOCATOR

The most popular section of the M.T.H. website can be found here. This is where visitors come looking to locate a particular product within the vast M.T.H. Authorized Retailer network. Developed in 1999, no other manufacturer has yet created a service like this for their customers. With over 7,000 items in the M.T.H. product line, this tool is your best bet for finding a hard-to-get M.T.H. item.



VIEW A CATALOG

The latest products featured in each M.T.H. catalog can be seen here. This is a popular destination for customers waiting for a new catalog to arrive in the mail. Sign up for our free electronic newsletter and you'll be notified when a new catalog has been posted online. You'll have all the news and details before any of your friends.



SHIPPING SCHEDULE

Keeping track of all those M.T.H. items would be an impossible task without our online shipping schedule. We update the schedule every week with the latest monthly releases. You can access this information directly or from the Product Locator section.

M.T.H. HOMEPAGE FIND IT HERE

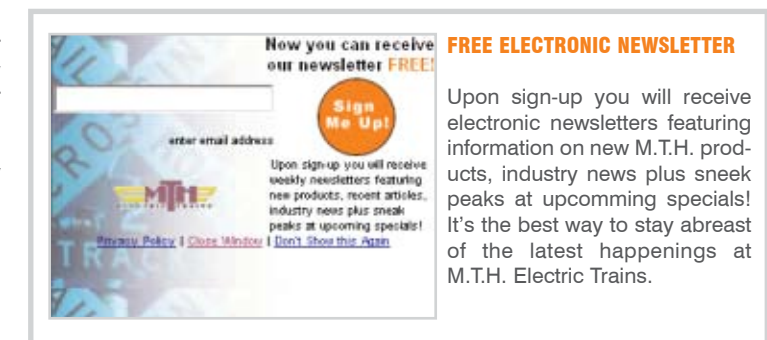

WWW.MTHTRAINS.COM



Not all products depicted in this catalog are production models. In some cases, the items pictured may be HO, O Scale or some other scale product. All item's graphic features and content are subject to change after publication. All product features may be verified on their retail packages. M.T.H. Electric Trains is in no way affiliated with any of the railroads featured in this catalog.

©2007, M.T.H. Electric Trains, 7020 Columbia Gateway Drive, Columbia Maryland 21046-1532 o www.mthtrains.com o 410/381-2580

MTH Trademarks: M.T.H. Electric Trains®, M.T.H.®, MTH Railroaders Club™, Ives®, Loco-Sound™, Proto-Sound® 2.0, Proto-Speed Control™, Proto-Doppler™, Proto-Dispatch™, Proto-Cast™, ProtoSmoke™, Proto-Coupler™, Proto-Effects™, RailKing®, Rugged Rails®, RailKing One-Gauge™, RailTown™, Tinplate Traditions™, ScaleTrax™, RealTrax®, Z-500™, Z-750™, Z-4000®, Z-1000™, Z-4000 Remote Commander™, DCS™ and the MTH Numbering System and all others indicated throughout this catalog. RealTrax® layouts created with RR-Trax™ which is a registered trademark of R&S Enterprises.

Greyhound is a registered trademark of the Greyhound Lines, Inc.

A licensed product of H.J. Heinz Company, L.P. ©2007

©2007 Anheuser-Busch, Inc. All Rights Reserved.*

© 2007 Caterpillar CAT, CATERPILLAR, their respective logos, "Caterpillar Yellow" and the POWER EDGE trade dress, as well as corporate and product identity used herein, are trademarks of Caterpillar and may not be used without permission.

Major League Baseball trademarks and copyrights are used with permission of Major League Baseball Properties, Inc. MLB.com MTH Trains/MLB 2007

©2007, NFL Enterprises LLC. NFL and the NFL Shield design are registered trademarks of the National Football League. The team names, logos and uniform designs are registered trademarks of the teams indicated.

© 2007 Molson Coors Global Properties, LLC. Coors trademarks are properties of Molson Coors Global Properties, LLC, used under license by M.T.H. Electric Trains. M.T.H.'s RealTrax has received U.S. Patent No. 6,019,289. M.T.H.'s ScaleTrax switches have received U.S. Patent No. 6,491,263. M.T.H.'s Z-4000 Transformer has received U.S. Patent No's 6,281,606 & 6,624,537. M.T.H.'s Proto-Scale 3-2 has received U.S. Patent No. 6,662,917. Some images used in this publication © 2004 www.clipart.com

© 2007 H-D, All Rights Reserved. Manufactured by M.T.H. Electric Trains under license from Harley-Davidson Motor Company.

Rudolph the Red-Nosed Reindeer © and © The Rudolph Company, L.P. "Rudolph the Red-Nosed Reindeer" animated program © Classic Media, Inc. All rights reserved.

Products bearing Southern Pacific, and Union Pacific marks are made under trademark license from Union Pacific Railroad Company.

Lionel is a registered trademark of Lionel Trains LLC. TMCC®, TrainMaster®, CAB-1® Remote Controller, and Lionel® are all registered trademarks owned by Lionel L.L.C. All Rights Reserved.

M.T.H.'s DCS Digital Command System has received U.S. Patent No. 6,457,681. M.T.H.'s Proto-Sound 2.0 system has received U.S. Patent No's 6,457,681 B1 (sound system), 6,457,681 B1 (Proto-Speed Control), 6,604,641 (Proto-Coupler), 6,280,278 (Proto-Smoke).

M.T.H.'s RealTrax has received U.S. Patent No. 6,019,289. M.T.H.'s ScaleTrax switches have received U.S. Patent No. 6,491,263. M.T.H.'s Z-4000 Transformer has received U.S. Patent No's 6,281,606 & 6,624,537. M.T.H.'s Proto-Scale 3-2 has received U.S. Patent No. 6,662,917. Some images used in this publication © 2004 www.clipart.com

Rudolph the Red-Nosed Reindeer®



Figures are Not Included

Rudolph the Red-Nosed Reindeer® - 2-8-0 Steam R-T-R Train Set

30-4173-1 w/Proto-Sound® 2.0 \$349.95
 30-4173-0 w/Loco-Sound™ \$279.95

Loco-Sound™ engines are equipped with transformer activated bell and whistle sounds only.

Rudolph the Red-Nosed Reindeer® Flat Car w/ Billboard

30-76254 \$39.95



Rudolph the Red-Nosed Reindeer® - Elves 4-Bay Hopper

30-75246 \$42.95

A train set is a great way to start your family's model railroading tradition and our RailKing Rudolph the Red-Nosed Reindeer® set might be your perfect choice. The locomotive is decorated in red & black colors and sports a red headlight to guide Santa's train through the countryside. This creative adaptation of a 2-8-0 Consolidation locomotive features a heavy all-metal steam engine boiler and chassis that feels as strong as it runs. The all-metal gears, wheels and axles will ensure a lifetime of fun and the unique sounds of Proto-Sound 2.0 will amaze your friends and family.

Imagine their faces when the whistle wails or the exclusive Rudolph® Proto-Effects begin playing sound clips from one of television's most timeless Christmas shows. Of course, seeing the synchronized puffing smoke from the locomotive as it pulls its three distinctive freight cars — each equipped with sprung die-cast metal trucks and operating metal couplers — is even more impressive and tells all who see it that this is one great set. As with all RailKing Ready-to-Run sets, the 12-piece RealTrax® oval assembles in minutes and can be placed right on the carpet for a quick, temporary layout.



Rudolph the Red-Nosed Reindeer® Yukon Cornelius™ Box Car

30-74360 \$44.95



Rudolph the Red-Nosed Reindeer® Misfit Toys™ Box Car

30-74414 \$44.95



Rudolph the Red-Nosed Reindeer® Bumble™ Modern Tank Car

30-73236 \$44.95

LAYOUT BUILDERS

Expand your train set with Layout Builder track packages.

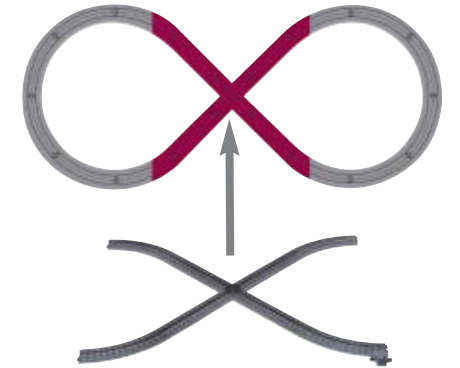
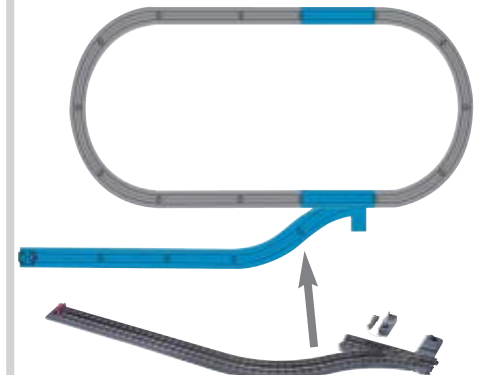

Figure 8 Layout Builder
 40-1025 \$49.95

Figure 8 Layout Builder Contains: (4) O-31 Curves, (4) 10" Straights, (1) Lighted Lockon, (1) 90 Degree Crossover



Left Hand Track Siding Layout Builder
 40-1026 \$79.95

Right Hand Track Siding Layout Builder (not shown)
 40-1027 \$79.95

Track Siding Layout Builder Sets Contain: (1) Left-Hand OR Right Hand O-31 Switch, (4) 10" Straights, (1) O-31 Curve, (1) RealTrax Bumper

Rudolph the Red-Nosed Reindeer © and © The Rudolph Company, L.P. "Rudolph the Red-Nosed Reindeer" animated program © Classic Media, Inc. All Rights Reserved.

PROTO-SOUND 2.0 SET FEATURES RUDOLPH® DIALOGUE AND MUSIC FROM THE CLASSIC TV SHOW





RAILKING
By MTH Electric Trains

Introduce someone you love to model railroading with the magic of a RailKing® Ready-To-Run trolley set or take advantage of the way it complements your own holiday decor when set up around the Christmas tree.

The colorful trolley features a lighted interior, metal wheels and gears and a long-lasting motor. The unit operates on any O Gauge track system including the easy-to-assemble RealTrax system found inside each set. Optional track bumpers can be added to take advantage of the Automatic Bumper Reversing Mechanism (ABRM) that changes the trolley's direction when it hits a track bumper.

Christmas Flat Car w/Fire Truck
30-76212 \$49.95



Christmas Flat Car w/Christmas Trees
30-76211 \$39.95



Automatic Bump-Reverse

While our trolley set comes with a circle of track, their bump-reverse feature allows continuous point-to-point operation as well. The trolley automatically reverses direction each time it hits a bumper.



8 Christmas Trolley R-T-R Train Set
30-4172-1 \$119.95



2007 Happy Holidays - Box Car
30-74443 \$39.95



Christmas Operating Box Car w/Signal Man
30-79189 \$59.95

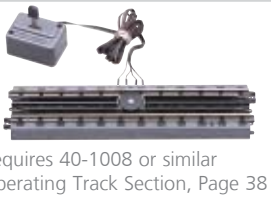

Requires 40-1008 or similar Operating Track Section, Page 38



Christmas - 6-Piece Figure Set
30-11062 \$24.95



2007 Christmas - Box Car
30-74442 \$39.95



2005 Christmas - Box Car
30-74257 \$39.95



2006 Christmas - Box Car
30-74357 \$39.95



Penguin Operating Aquarium Car
30-79190 \$69.95

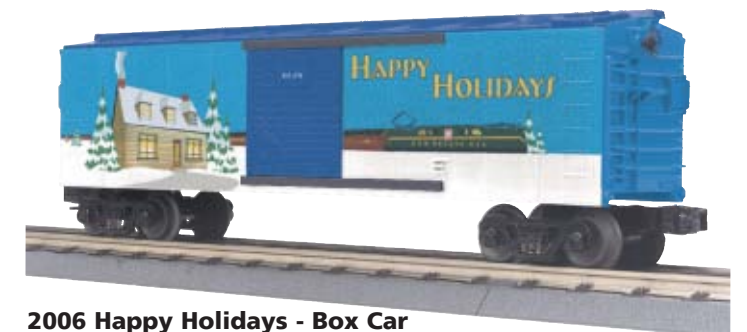

2006 Happy Holidays - Box Car
30-74356 \$39.95

4-6-0 Christmas Express Train Set

2-8-0 Pennsy Broadway Limited Train Set



Christmas - 4-6-0 Ten Wheeler Train Set

30-4156-1 w/Proto-Sound® 2.0 \$349.95
 30-4156-0 w/Loco-Sound™ \$279.95

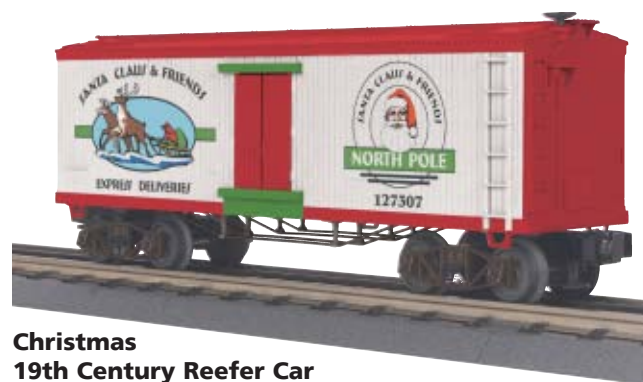

**Christmas
19th Century Reefer Car**
 30-78041 \$39.95

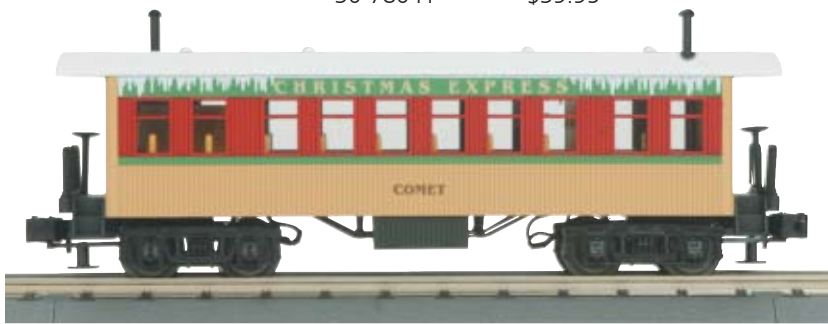

Christmas - Overton Passenger Coach
 30-6423 \$44.95

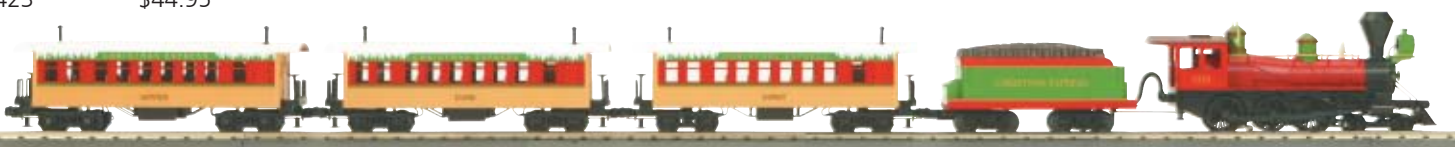

The Holiday season and model trains have always gone together. What better way to recreate this classic memory than to include a beautifully decorated set around your Holiday tree. Featuring bright, Holiday colors the Christmas 4-6-0 passenger set captures the spirit and fun of model railroading in an affordable train set that will last for years and years.

The unique sounds of Proto-Sound 2.0 will amaze your friends and family. Imagine their faces when the whistle wails or the exclusive Passenger Station Proto-Effects™ begin calling out Santa's next station stop on the line! Of course, seeing the synchronized puffing smoke from the locomotive as it pulls its three car passenger consist with die-cast metal trucks and operating metal couplers is even more impressive and tells all who see it that this is one great set. As with all RailKing® Ready-to-Run sets, the 12-piece RealTrax® oval assembles in minutes and can be placed right on the carpet or floor for a quick, temporary layout.



Pennsylvania - 2-8-0 Steam Passenger Train Set

30-4137-1 w/Proto-Sound® 2.0 \$349.95

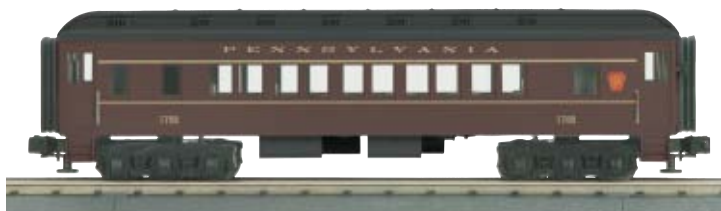

Pennsylvania - O-27 Madison Coach Car
 33-6224 \$44.95



Pennsylvania - O-27 Madison Diner Car
 33-6223 \$44.95



Pennsylvania - O-27 Madison Combine Car
 33-6225 \$44.95



For decades, the Pennsylvania Railroad was America's largest railroad, stretching from the East Coast to the Mid-West, moving untold amounts of freight and thousands of passengers every day. Although long gone, the spirit of the Pennsylvania is as strong today as it was in its heyday. Featuring a near-scale locomotive, the Pennsy Broadway 2-8-0 ready-to-run passenger train set comes decorated in classic Pennsylvania livery and features a heavy 2-8-0 steam locomotive with all-metal gears, wheels and axles to ensure a lifetime of fun.

The unique sounds of Proto-Sound 2.0 will amaze your friends and family. Imagine their faces when the whistle wails or the exclusive Passenger Station Proto-Effects™ begin calling out the next station stop on the line - just like the real stations! Of course, seeing the synchronized puffing smoke from the locomotive as it pull its three-car passenger consist with die-cast metal trucks and operating metal couplers is even more impressive and tells all who see it that this is one great set. As with all RailKing® Ready-to-Run sets, the 12-piece RealTrax® oval assembles in minutes and can be placed right on the carpet or floor for a quick, temporary layout.

2-8-0 Pennsy Freight Express Train Set ■■■ 2-8-0 Harley-Davidson® Electro-Glide Set



RAILKING
By M.T.H. Electric Trains



RAILKING
By M.T.H. Electric Trains

HARLEY-DAVIDSON © 2007 H-D, All Rights Reserved. Manufactured by M.T.H. Electric Trains under license from Harley-Davidson Motor Company. © 2007 M.T.H. Electric Trains, 7020 Columbia Gateway Drive, Columbia, Maryland 21046

Pennsylvania - 2-8-0 Steam Train Set

30-4136-1 w/Proto-Sound® 2.0 \$329.95
30-4136-0 w/Loco-Sound™ \$249.95



Pennsylvania - Tank Car
30-73221 \$42.95



Pennsylvania - Stock Car
30-7160 \$39.95



Pennsylvania Operating Box Car w/Signal Man
30-79186 \$59.95

A classic freight set is a great way to start your family's model railroading tradition and the Pennsylvania 2-8-0 Consolidation set makes a great beginning. Decorated in near black Pennsylvania Brunswick Green colors, this creative adaptation of the 2-8-0 features a heavy all-metal steam engine boiler and chassis that feels as strong as it runs. The all-metal gears, wheels and axles will ensure a lifetime of fun and the unique sounds of Proto-Sound 2.0 will amaze your friends and family.

Imagine their faces when the whistle wails or the exclusive Freight Yard Proto-Effects™ begin playing the sounds of a busy freight yard. Of course, seeing the synchronized puffing locomotive pull its three distinctive freight cars with sprung die-cast metal trucks and operating metal couplers is even more impressive and tells all who see it that this is one great set. As with all RailKing® Ready-to-Run sets, the 12-piece RealTrax® oval assembles in minutes and can be placed right on the carpet for a quick, temporary layout.



Pennsylvania - Gondola Car w/Crates
30-72011 \$39.95

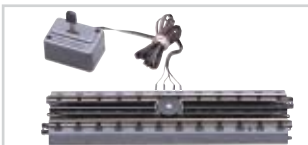

Requires 40-1008 or similar Operating Track Section, Page 38



Harley-Davidson® - 2-8-0 Steam Train Set

30-4181-1 w/Proto-Sound® 2.0 \$349.95



Harley-Davidson® - Ore Car
30-75248 \$39.95



Harley-Davidson® - Tank Car
30-73220 \$49.95

Harley-Davidson® Gondola Car w/Crates
30-72001 \$44.95



Harley-Davidson® 4-Bay Cylindrical Hopper Car
30-75247 \$44.95



Harley-Davidson® - Box Car
30-74439 \$44.95



Harley-Davidson® - 40' Window Box Car
30-74196 \$69.95

The Harley-Davidson® 2-8-0 Steam freight set is a great way to introduce a newcomer to model railroading. Decorated in classic Harley-Davidson® colors, this creative adaptation of the 2-8-0 steam engine features a heavy all-metal steam engine boiler and chassis that feels as strong as it runs. The all-metal gears, wheels and axles will ensure a lifetime of fun and the unique sounds of Proto-Sound® 2.0 will amaze friends and family alike.

Imagine their faces when the whistle wails or the exclusive Freight Yard Proto-Effects™ begin playing the classic sounds of Harley-Davidson® motorcycles loading up at the factory! Of course, seeing the synchronized puffing locomotive pull its three distinctive freight cars with sprung die-cast metal trucks and operating metal couplers is even more impressive and tells all who see it that this is one great set. As with all RailKing Ready-to-Run sets, the 12-piece RealTrax oval assembles in minutes and can be placed right on the carpet for a quick, temporary layout.

Opening Doors Reveal Two Motorcycles Inside!

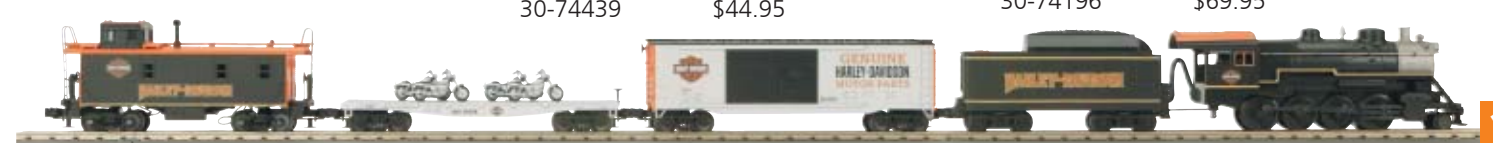

2-8-0 New York Central Freight Train Set ■ 2-8-0 Anheuser-Busch Adolphus Train Set



New York Central - 2-8-0 Steam Train Set

30-4185-1 w/Proto-Sound® 2.0 \$329.95
 30-4185-0 w/Loco-Sound™ \$249.95

New York Central - Reefer Car

30-78042 \$39.95



New York Central Operating Box Car w/Signal Man

30-79188 \$59.95



Requires 40-1008 or similar Operating Track Section, Page 38



New York Central Engineering Car

30-79169 \$44.95

For much of the twentieth century, the chief rival of the mighty Pennsylvania Railroad was the New York Central. While the Pennsy headed west by conquering the Appalachian Mountains, the NYC followed an easier but less direct route, up the Hudson River Valley and then west along the shores of the Great Lakes - leading the NYC to advertise itself as the Water Level Route. The Central's mainline along the Hudson River was the first four-track long-distance railroad in the world. Along this raceway sped freight bound for the Midwest and passenger trains that included the New York-to-Chicago Twentieth Century Limited, one of the most famous and luxurious trains in the world.

Recreate the drama of fast freight traffic on the Water Level Route with this rugged and colorful train set, complete with die-cast metal steam engine featuring puffing smoke and bell, whistle, and freight yard sounds. For even more fun, add an operating dump car or a boxcar with a signal man who pops out to signal the engineer.



Anheuser-Busch - 2-8-0 Steam Train Set

30-4155-1 w/Proto-Sound® 2.0 \$349.95

Who says model trains are just for kids? This beautifully decorated "adult collectible" train set is a great way to begin your own model railroading tradition and comes fully equipped with a load of features that are sure to entertain. Decorated in black & red Anheuser livery, this creative adaptation of the 2-8-0 features a heavy all-metal steam engine boiler and chassis that feels as strong as it runs. The all-metal gears, wheels and axles will ensure a lifetime of fun and the unique sounds of Proto-Sound 2.0 will amaze your friends and family.

Imagine their faces when the whistle wails or the exclusive Anheuser-Busch Proto-Effects begin playing the classic Budweiser theme song. Of course, seeing the synchronized puffing locomotive pull its three distinctive freight cars each outfitted with sprung die-cast metal trucks and operating metal couplers is even more impressive and tells all who see it that this is one great set. As with all RailKing Ready-to-Run sets, the 12-piece RealTrax oval assemblies in minutes and can be placed right on the carpet for a quick, temporary layout.



Budweiser - Modern Reefer Car

30-78033 \$44.95



Budweiser - Modern Tank Car

30-73226 \$49.95



2-8-0 Caterpillar® Freight Mover Set



Caterpillar® - 2-8-0 Steam Train Set
30-4180-1 w/Proto-Sound® 2.0 \$349.95



Caterpillar® - 4-Bay Hopper Car
30-75245 \$42.95



Caterpillar® - Crane Car
30-79182 \$59.95



Caterpillar® - Modern Tank Car
30-73224 \$49.95



Caterpillar® - Gondola Car w/Crates
30-72002 \$44.95



Caterpillar® 40' High Cube Box Car
30-74378 \$49.95

The story of Caterpillar® dates back to the late 19th century when Daniel Best and Benjamin Holt each searched for ways to harness the promise of steam tractors for farming. As their respective companies mastered the development of gasoline-powered track-type tractors in the 1920's, it only seemed natural that they combine their expertise. By 1925, they did just that to form the Caterpillar® Tractor Company.

We've created a special train set, naturally featuring a steam locomotive, to celebrate the early Caterpillar® years when Best and Holt utilized steam power to create their earliest tractors. Our creative adaptation of the 2-8-0 steam locomotive features a heavy all-metal steam engine boiler and chassis that feels as strong as it runs. The metal gears, wheels and axles ensure a lifetime of fun and the unique sounds of Proto-Sound 2.0 will amaze your friends and family.

They'll watch in amazement as the synchronized puffing locomotive pulls its three distinctive freight cars, each equipped with sprung die-cast metal trucks and operating metal couplers. As with all RailKing Ready-to-Run sets, the 12-piece RealTrax oval assembles in minutes and can be placed right on the carpet for a quick, temporary layout.



© 2007 Caterpillar CAT, CATERPILLAR, their respective logos, "Caterpillar Yellow" and the POWER EDGE trade dress, as well as corporate and product identity used herein, are trademarks of Caterpillar and may not be used without permission.



4-8-4 Bantam J Freight Train Set



Norfolk & Western - 4-8-4 Bantam J Steam Freight Set
30-4184-1 w/Proto-Sound® 2.0 \$329.95

Norfolk & Western Stock Car
30-7171 \$39.95



Norfolk & Western 3-Dome Tank Car
30-73237 \$42.95

Often called "The Last Steam Railroad in America," the Norfolk & Western relied totally on steam power until well into the 1950s, when most other railroads had already converted to diesels. The N&W's loyalty to steam was prompted by two factors. The N&W was mainly a coal-hauling railroad with most of its trackage in Virginia, West Virginia, and Ohio, so fuel was abundant and cheap. Perhaps more important, the N&W built some of the best steam engines ever made, in its own shops in Roanoke, VA. Among the finest of these was the Class J, a streamlined greyhound that could cruise at well over 90 mph. One of these massive 4-8-4 Northerns survives today at the Virginia Museum of Transportation, not far from the shops where it was born.

Recreate the Norfolk & Western's daily conquest of the Appalachian Mountains with this rugged freight set. Headed by a powerful Class J Northern, this set features all-metal trucks and couplers, RealTrax® that can be set up quickly on a carpet or floor, puffing smoke, and CD-quality sounds that include freight yard sound effects and the Class J's beautiful whistle, bell, and deep chuff.



4-8-4 Bantam Daylight Steam Train Set

4-8-4 Bantam J Passenger Train Set



Southern Pacific - 4-8-4 Bantam Daylight Steam Passenger Set
30-4182-1 w/Proto-Sound® 2.0 \$349.95



Southern Pacific - O-27 Streamlined Full-Length Vista Dome Car
33-6034 \$44.95



Southern Pacific - O-27 Streamlined Combine Car
33-6033 \$39.95



Southern Pacific - O-27 Streamlined Coach Car
33-6032 \$39.95



Norfolk & Western - 4-8-4 Bantam J Steam Passenger Set
30-4183-1 w/Proto-Sound® 2.0 \$349.95



Norfolk & Western - O-27 Streamlined Coach Car
33-6027 \$39.95



Norfolk & Western - O-27 Streamlined Combine Car
33-6028 \$39.95

**Norfolk & Western
O-27 Streamlined Full-Length Vista Dome Car**
33-6026 \$44.95



In 1937 the Southern Pacific Railroad trumpeted a new train in full-page magazine ads:

Let us stand by the tracks of Southern Pacific's Coast Line, as thousands now do every day and listen...Suddenly from far off comes a musical note, rising. Round a curve flashes a streak of color. Here comes the Daylight, the most beautiful train in the West!

Presenting a glorious splash of orange and red from locomotive to observation car, the Daylights linked Los Angeles and San Francisco "in a glorious daylight trip, streaking along the Pacific Ocean for more than a hundred breathless miles." Leading the trains were the Southern Pacific's class GS (for "Golden State") 4-8-4 Northern, arguably among the handsomest steam engines ever built.

A lone GS-4, No. 4449, was saved from the scrapper and placed on display in a Portland, Oregon park, where it sat silent for nearly two decades. An elderly gentleman was a regular visitor to the locomotive, oiling its lubrication points to prevent rusting. In part because of his efforts, No. 4449 was in good enough shape to be restored in 1975 to pull the American Freedom train in celebration of our nation's 200th anniversary. Repainted in Daylight colors, the engine operates today in excursion service.

Like the Daylight 4-8-4's, the Norfolk & Western's Class J Northern represented steam power at its zenith. Fast, powerful, and pleasing to the eye, they were the last hurrah of steam power before diesels sent them to the scrap heap. The final three J's, built in 1950 in the N&W's own shops in Roanoke, VA, were the last steam passenger engines built for an American railroad. They sped across the Appalachian Mountains daily between Norfolk, VA and Cincinnati, OH, hauling passenger trains that included the Powhatan Arrow, the Pocahontas and the Cavalier. With authentic Norfolk & Western station announcements and CD-quality steam engine sounds, this set recalls the excitement of luxury passenger travel in the steam era, when locomotive whistles echoed off Virginia and West Virginia mountainsides.

The Silver Bullet® Steam Set



Coors Light Silver Bullet Train Set
30-1433-1 w/Proto-Sound® 2.0 \$499.95



Power and Track Pack
40-1071 \$149.95



Coors Light - Modern Reefer Car
30-78032 \$44.95



Coors Light - Tank Car
30-73223 \$49.95



Coors Light Silver Bullet - Operating Reefer Car
30-78040 \$79.95

You asked for it! Since The Silver Bullet® Train debuted in a 2004 TV ad, this imaginary train has been one of our most-requested items. For 2007, we've chosen this silver flyer to introduce a feature that has been latent in Proto-Sound 2.0 but never used before: the ability of a locomotive to "talk to" its trailing cars or trackside accessories. At your command, The Silver Bullet® steam engine pulls into a station, playing arrival and departure sounds inspired by the television commercials and commanding its three-reefer consist to open its doors, billowing frosty smoke and revealing its chilled contents. Of course the chrome-plated Silver Bullet includes all the features found in every Proto-Sound 2.0 steamer, including a suite of sound effects, synchronized puffing smoke, and smooth cruise control operation at any throttle setting from a crawl to a speeding bullet.

Soon after its introduction in 1978, Coors nicknamed its light beer The Silver Bullet® because of its sleek aluminum silver can. The Silver Bullet® Train delivering ice-cold refreshment from the Rocky Mountains is the brainchild of FCB-Chicago, a division of famed advertising agency Foote Cone & Belding. Although this is Coors' first use of a train as a corporate symbol, the firm has long been a major shipper and receiver of products by rail. Today its Golden, Colorado brewery operates diesel switchers emblazoned with the Coors logo and sends out approximately 300 rail cars of beer every week.

Add a touch of pure fantasy and a great deal of fun to your layout with The Silver Bullet® Train and its frosty load. Activate its unique features with virtually any conventional transformer with bell and whistle buttons, or use the M.T.H. DCS system (see page 44) for an even more exciting operating experience.



F-3 Santa Fe Diesel Passenger Set



Santa Fe - F-3 Passenger Train Set
30-4186-1 w/Proto-Sound® 2.0 \$329.95



Santa Fe - O-27 Streamlined Full-Length Vista Dome Car
33-6031 \$44.95



Santa Fe - O-27 Streamlined Combine Car
33-6030 \$39.95



Santa Fe - O-27 Streamlined Coach Car
33-6029 \$39.95

For luxury travel between Chicago and Los Angeles, the Santa Fe was the way to go. Highballing through the Southwest's deserts and mountains, Santa Fe streamliners like the Chief, Super Chief, and El Capitan were rolling hotels where one could eat like a king and be lulled to sleep by the gentle rhythm of the rails. Santa Fe streamliners were a favorite means of travel for movie stars, and in 1951 the railroad was the first to introduce dome cars on the Chicago-L.A. route.

Imagine you're on your way to Hollywood in this Santa Fe passenger set. Each car (except the baggage car) has a detailed, lighted interior. The engine features authentic Santa Fe station announcements and CD-quality bell, horn, and diesel motor sounds. Add additional matching cars for even more fun - this twin-motored diesel has plenty of power to pull them!

F-3 Santa Fe Diesel Freight Set



Santa Fe - F-3 Freight Train Set
30-4187-1 w/Proto-Sound® 2.0 \$299.95



Santa Fe - Dump Car w/Operating Bay
30-79185 \$49.95

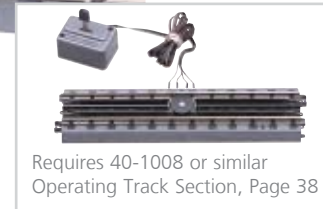

Requires 40-1008 or similar Operating Track Section, Page 38



Santa Fe - Flat Car w/ Trailer
30-76255 \$49.95

The Atchison, Topeka and Santa Fe Railway stretched from Chicago to the Gulf of Mexico and the Pacific Ocean. Almost everywhere in the Midwest and the Southwest, Santa Fe trains were a part of daily life, carrying passengers and freight for more than a century.

Decorated in the Santa Fe's yellow and blue freight colors, Santa Fe diesels hustled freight across plains, through deserts, and over mountains until 1996, when the AT&SF merged with the Burlington Northern to form the Burlington Northern Santa Fe - which is today one of America's largest and most successful railroads.

Move the freight on your own railroad with this colorful Santa Fe set, headed by a powerful twin-motored diesel equipped with digital sound and the revolutionary speed control found only in M.T.H. locomotives. For even more fun, add extra cars decorated for the Santa Fe or other railroads, including a remote control dump car that delivers its load at your command.



Scale GP-9 Union Pacific Diesel Set

SW-1500 Diesel Train Set



Features ProtoSmoke™ Diesel Exhaust

Union Pacific - Scale GP-9 Deluxe Freight Train Set
30-4189-1 w/Proto-Sound® 2.0 \$349.95



Union Pacific Flat Car w/(2) SL55 Mercedes
30-76167 \$39.95

Union Pacific - Ore Car
30-75244 \$39.95



Union Pacific Operating Box Car w/Signal Man
30-79187 \$59.95

At your command, box car door opens and signal man with lighted lantern pops out to signal the engineer; requires remote control track section for activation, sold separately, such as no. 40-1008 RealTrax operating track, page 38



Union Pacific Flat Car w/(2) Ford Rancheros
30-76247 \$39.95



Union Pacific - Gondola Car w/Crates
30-72012 \$39.95

On May 10, 1869, the Union Pacific and Central Pacific railroads met at Promontory Point, Utah to complete the first transcontinental railroad. Wagon trains and clipper ships were no longer the only way to the West Coast. More than a century later, the Central Pacific is gone but the Union Pacific is the largest railroad in North America, with more than 8,000 locomotives, 100,000 freight cars, and 32,000 miles of track in 23 states. Due to shared motive power agreements with other railroads, its famous Armour Yellow diesels can be spotted anywhere from Los Angeles to Boston. Proud of its long history, the UP also operates a Heritage Fleet of locomotives that includes Challenger No. 3985, the world's largest operating steam locomotive.

Recreate the excitement of mainline railroading in the American West with this colorful freight set that includes a GP9 diesel with smoking exhaust and twin motors to pull your heaviest loads. For more information on the history of the Union Pacific Railroad and what it does today, visit the company's Web site at www.uprr.com.



Alaska - SW-1500 Diesel Train Set
30-4158-1 w/Proto-Sound® 2.0 \$329.95



Alaska - Engineering Car
30-79167 \$44.95



Alaska - Flat Car w/Operating Helicopter
30-79175 \$59.95



Alaska - Tank Car
30-73222 \$42.95



Requires 40-1008 or similar Operating Track Section, Page 38

Created by an act of Congress in 1914, the Alaska Railroad was owned and operated by the U.S. government until 1985, when the State of Alaska became the railroad's new owner. The railroad helped develop the state's economy and played a strategic role in World War II. It continues to thrive today, carrying lumber and petroleum products out of the Alaska wilderness to its southern ports, and giving tourists - more than a half-million of them a year - great views of Alaska's majestic beauty.

Recreate the excitement of this wilderness railroad with this hard-working M.T.H. diesel set featuring three colorful, highly-detailed cars. With its twin flywheel-equipped motors and rubber traction tires, the Alaska Railroad SW-1500 diesel is ready for the heaviest trains on your railroad. For even more fun, add an operating helicopter car to scout for hazards on the track ahead. As with all Proto-Sound 2.0 locomotives, the Alaska RR diesel offers amazing slow speed capability, Proto-Speed Control™ at all speeds from a crawl to full throttle, and a wide range of dramatic railroad sounds.



Scale RS-3 Canadian Pacific Set

Scale RS-3 Pennsy Diesel Freight Set



RAILKING
scale

Canadian Pacific - Scale RS-3 Deluxe Freight Train Set
30-4178-1 w/Proto-Sound® 2.0 \$329.95



Canadian Pacific - Bunk Car
30-79159 \$44.95



Canadian Pacific - Fire Car
30-79171 \$49.95



Canadian Pacific - Gondola Car w/Crates
30-72009 \$39.95



Canadian Pacific - Crane Car
30-79181 \$59.95



On July 1, 1867, the new country of Canada was created by the confederation of Nova Scotia, New Brunswick, and what is today Quebec and Ontario. The eastern provinces were enticed into the deal by the guarantee of a railroad link to the central provinces. Four years later, the promise of a transcontinental railroad brought British Columbia, on the west coast, into confederation as well. The Canadian Pacific Railway Company was created to fulfill those promises, and in 1885 the last spike was driven at Craigellachie, B.C., binding together the second-largest nation on earth. Today 14,000 miles of CPR track extend from Montreal to Vancouver and deep into the U.S., through the CPR's ownership of what once was the Milwaukee Road, the Soo Line, and the Delaware & Hudson Railway.

Decorated in classic CPR livery, this freight set features a powerful, twin-motored RS-3 diesel to help you recreate the CPR's conquest of the Canadian plains, mountains, and wilderness. For more information on the Canadian Pacific, including a Children's History of the CPR, visit the company's Web site at www8.cpr.ca.

RailKing Scale engines are full O scale models that are 1/48 the size of the real locomotive. Other RailKing® engines, such as our 2-8-0 and Bantam steam locomotives, have somewhat scaled-down proportions because a full-scale model would not negotiate the tight curves found on most toy train layouts.



RAILKING
scale

Pennsylvania - Scale RS-3 Deluxe Freight Train Set
30-4179-1 w/Proto-Sound® 2.0 \$329.95



Pennsylvania - Hopper Car
30-75187 \$34.95

Pennsylvania Dump Car w/Operating Bay
30-79139 \$49.95



Pennsylvania - Reefer Car
30-78002 \$39.95



Once one of the largest builders of steam engines, the American Locomotive Company introduced its diesel RS "road switchers" in 1941, pioneering a look that would revolutionize diesel power. Unlike streamlined engines with a cab in front and a full-width body - like the Santa Fe F-3 diesels elsewhere in this catalog - the ALCo RS-series had narrow hoods and outside walkways with doors that opened into the engine compartment. Mechanics loved the engine because it was easier to service, and train crews liked the better visibility to the rear for switching moves. Electro-Motive Division, the largest diesel builder at the time, copied the road switcher, or "hood unit," configuration with its GP7 and GP9. The look of the diesel had changed forever, and most of today's engines are descendants of those early ALCo RS road switchers.

Recreate the diesel revolution on the mighty Pennsylvania railroad with this authentic 1950s freight set - complete with a unique Pennsy-style caboose and twin-motored RS-3 diesel featuring horn, bell, accurate ALCo diesel sounds, and freight yard sound effects for your hard-working railroad.

Scale F-3 Diesel Train Set



Santa Fe - Scale F-3 Deluxe Passenger Train Set
30-4144-1 w/Proto-Sound® 2.0 \$499.95

Chrome-Plated!



Santa Fe - 60' Streamlined ABS Coach Car
30-67214 \$49.95



Santa Fe - 60' Streamlined ABS Full-Length Vista Dome Car
30-67215 \$49.95

Put your railroad to work with this deluxe Santa Fe Ready-To-Run diesel passenger set. Bearing the markings of one of America's most famous railroads, this scale sized set makes a great beginning for any family's first model train.

The scale sized Santa Fe F-3 diesel's classic warbonnet livery has been brightened up thanks to the chrome plated car body that houses the locomotive's powerful 2-motored chassis. Outfitted with all-metal wheels and gears, the engine runs as good as it looks and comes equipped with digital sound and revolutionary speed control features found only in RailKing Ready-to-Run train sets. Included are three well detailed 60' chrome plated passenger cars, each outfitted with a detailed interior and all-metal trucks, operating couplers, and metal wheels and axles ensuring years and years of fun operation.

Imagine the faces of friends and family when the horn wails or the exclusive Passenger Station Proto-Effects™ begin playing the sounds of a busy train station - calling out the next train and destination. Of course, seeing the flash of chrome and color when the locomotive rushes past while pulling its three distinctive cars is even more impressive and tells all who see it that this is one great set. As with all RailKing® Ready-to-Run sets, the 12-piece RealTrax® oval assemblies in minutes and can be placed right on the carpet or floor for a quick, temporary layout.



Scale GP-9 Diesel Train Set



New York Central - Scale GP-9 Deluxe Freight Train Set
30-4188-1 w/Proto-Sound® 2.0 \$329.95



New York Central Dump Car w/Operating Bay
30-79184 \$49.95

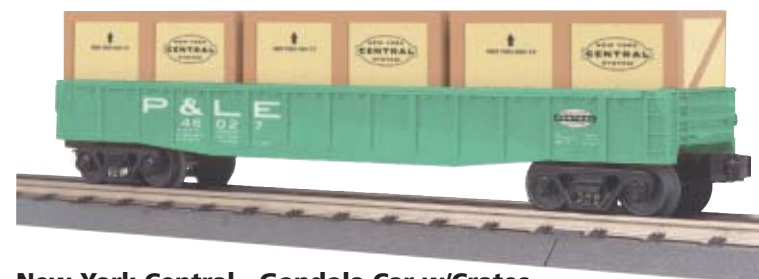

New York Central - Gondola Car w/Crates
30-72010 \$39.95



In the middle of the twentieth century, the New York Central was the second-largest railroad in the nation, exceeded only by the Pennsylvania Railroad. The Central's high-speed main lines and less-traveled secondary lines served the industrial heartland of America, from Boston and New York to Chicago and St. Louis. When the NYC replaced its nearly 5000 steam locomotives with diesels in the 1940s and 1950s, it painted its new engines in a dramatic "lighting stripe" scheme to symbolize the railroad's power and speed. And the most popular of those "first-generation" diesels - the locomotives that sent steam to the scrap heap - were the GP9 and its older brother, the GP7, made by the Electro-Motive Division of General Motors.

Move some heavy freight traffic on your own railroad with this highly detailed New York Central set. Its twin-motored GP9 diesel features authentic lightning stripe livery, complete with "zebra stripes" on the pilots for safety, to make the engine more visible to the switching crew. Our NYC "Geep" also features exhaust smoke, accurate bell, horn, and diesel motor sounds, and the freight yard sounds of a hard-working railroad.

Scale RS-3 Steelers Deluxe Diesel Freight Set



RAILKING
scale

Featuring Exciting NFL Radio Play-by-Play Proto-Effects™ Of Steeler games.

This modern O Gauge freight set brings the rugged excitement of the NFL to model railroading in detailed scale realism that any Pittsburgh Steelers fan will appreciate.

Headed up by a powerful twin-motored RailKing Scale RS-3 diesel locomotive sporting the NFL Pittsburgh Steelers colors, this set will perform like an NFL All-Pro. The all-metal gears, wheels and axles will ensure a lifetime of fun and the unique sounds of Proto-Sound 2.0 will amaze your friends and family.

A press of the whistle button sounds the shrill of a referee's whistle while activating the bell triggers the stadium PA introduction of the Steelers. Even more impressive are our exclusive NFL Proto-Effects that play back classic Pittsburgh Steelers radio play-by-play calls.

Of course, seeing this colorful locomotive pull its three-car consist is even more impressive and tells all who see it that this is one great set. As with all RailKing Ready-to-Run sets, the 12-piece RealTrax oval assembles in minutes and can be placed right on the carpet or floor for a quick, temporary layout.



Pittsburgh Steelers - Scale RS-3 Deluxe Freight Train Set
30-4177-1 w/Proto-Sound® 2.0 \$349.95



Pittsburgh Steelers - Dump Car w/Operating Bay
30-79180 \$54.95

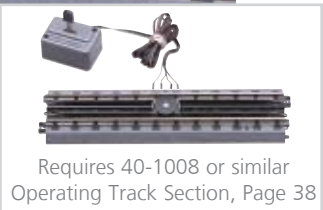

Requires 40-1008 or similar Operating Track Section, Page 38



Pittsburgh Steelers 40' High Cube Box Car
30-74362 \$49.95



Pittsburgh Steelers - 40' Window Box Car w/Helmets
30-74286 \$64.95



Pittsburgh Steelers - Slag Car
30-79179 \$44.95

Pittsburgh Steelers Lighted Billboard
30-90207 \$29.95



Pittsburgh Steelers #193 Industrial Water Tower
30-90209 \$54.95



Pittsburgh Steelers - Bus Station
30-90211 \$129.95
Includes Flashing Lights & Die-Cast Bus!



Pittsburgh Steelers - Die-Cast Bus
30-50038 \$29.95

Pittsburgh Steelers Trolley Set



Pittsburgh Steelers Trolley Train Set
30-4169-1 \$129.95

Features:

Set Features:

- Operating Trolley Car
- RailWare™ Interactive DVD With Track Layout Software
- 31" x 31" 8-Piece RealTrax® Oval
- ZDC Transformer With Controller
- Lighted Track Lock-On

Trolley Features:

- Detailed ABS Body
- Powerful Motor
- Automatic Reversing Bumpers
- Operating Headlight
- Moveable Power Pole
- Lighted Interior
- All-Metal Wheels and Gears
- Measure: 8 1/4" x 2 3/8" x 3 1/3"
- Operates On O-27 Curves



© 2007, NFL Enterprises LLC. NFL and the NFL shield design are registered trademarks of the National Football League. The team names, logos and uniform designs are registered trademarks of the teams indicated.

260E Christmas O-Gauge Steam Set



TINPLATE TRADITIONS
By M.T.H. Lionel Trains

Brighten your house for the holidays with the gleaming sheet metal beauty of the tinplate era. This holiday freight set harks back to the era between the two World Wars, when toy trains indeed looked like toys. The original 260E locomotive, produced by Lionel® through 1935, represented the last hurrah of tinplate. Within a few years, most toy trains would be far more realistic - if less charming - plastic and die-cast models of real-life trains.

Decorated with bright metal trim and colorful baked enamel paint, this freight set runs on the same O gauge RealTrax® as every RailKing® model in this catalog. And while its exterior is pure 1930s, thanks to Proto-Sound® 2.0 electronics our 260E steamer delivers smoother operation than any original tinplate locomotive, as well as huge plumes of puffing smoke - timed to the driver's revolutions - and a clanging bell and wailing whistle guaranteed to delight children of all ages.

What is Tinplate?

In any scale or gauge, model railroading can be a time machine, taking us back to the trains of another era and the world they inhabited. Like the originals, M.T.H. Tinplate Traditions™ models are made of stamped and die-cast metal and finished in bright metal plating and shiny baked enamel paint. They are the toys of a time when silent movies and then radio were among the chief forms of entertainment - a period when playthings and entertainment were not intended to be realistic, but to serve as springboards for a child's imagination.



Tinplate Traditions trains come in two sizes: O gauge, like the RailKing trains shown elsewhere in this catalog, and Standard Gauge, which is almost twice the size of O gauge and peaked in popularity in the 1920s and early 1930s.

Christmas - 260E Steam Freight Set
10-3036-1 w/Proto-Sound® 2.0 \$599.95



Christmas - 2800 Series O Gauge Gondola Car
10-8072 \$79.95



Christmas - 2800 Series O Gauge Cattle Car
10-8070 \$79.95



Shamrock Oil & Gas - 2800 Series O Gauge Tank Car
10-8066 \$79.95

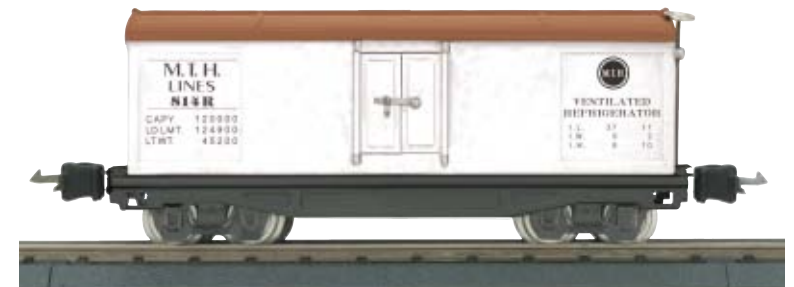

White & Brown - 2800 Series O Reefer Car
10-8025 \$79.95



260E Pennsy O-Gauge Steam Set

No. 384 Christmas Standard Gauge Set



Pennsylvania - 260E Steam Freight Set
10-3035-1 w/Proto-Sound® 2.0 \$599.95



Pennsylvania 2800 Series O Gauge Gondola Car
10-8074 \$79.95



Altoona 36 Lager 2800 Series O Gauge Reefer Car
10-8053 \$79.95



Islay's 2800 Series O Gauge Tank Car
10-8065 \$79.95



Bessemer & Lake Erie 2800 Series O Gauge Gondola Car
10-8060 \$79.95

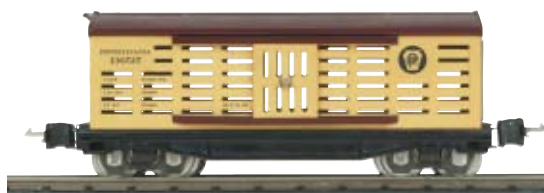

Pennsylvania 2800 Series O Gauge Cattle Car
10-8071 \$79.95

Like its larger standard gauge cousins on the following pages, this Pennsylvania Railroad steam set embodies the gleaming sheet metal beauty of the tinplate era. Lionel® spared no hyperbole in introducing the original 260E locomotive in 1930: "Boys - here is the most remarkable "O" Gauge Steam Type Locomotive that has ever been produced. Dozens of blue prints and photographs of famous new locomotives from railroads all over the country were examined, and the best features of each were utilized by Lionel's Engineering Department in designing this locomotive. It is built for speed and power. It is low, long, graceful and sturdy. Complete with its Pacific type oil-burning tender, it represents a miracle of model railroad engineering. It will be the pride of every boy who owns one."

Unlike the original, our replica of the 260E produces huge plumes of puffing smoke as well as clanging bell, wailing whistle, and deep chuffing sounds appropriate for what Lionel called its "Mogul of the Rails." Our 260E is also outfitted with a "Latch-Type" Proto-Coupler™ that can be remotely activated by the transformer to uncouple from its trailing three freight cars, each decorated with bright metal trim and colorful baked enamel paint.



Christmas - No. 384 Steam Passenger Set
10-1295-1 w/Proto-Sound® 2.0 \$599.95

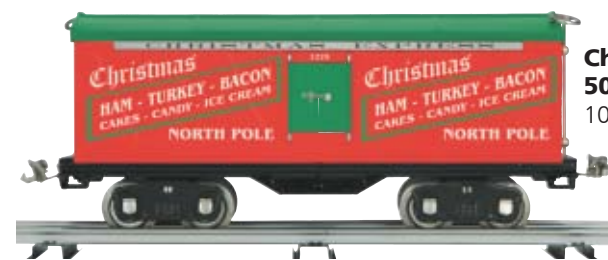

Christmas 500 Series Std. Gauge Reefer Car
10-2224 \$99.95

Christmas (Donner) 330 Series Passenger Car
10-5090 \$149.95

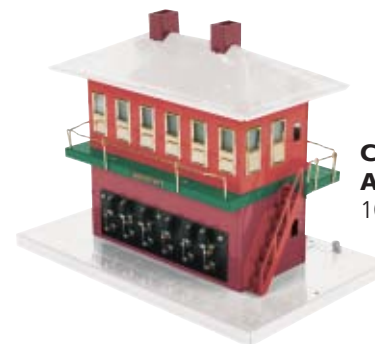

Christmas AF Std. Gauge Switch Tower
10-4061 \$299.95



Christmas - 330 Series Baggage Car
10-5077 \$149.95

In many respects, the No. 384 is the quintessential standard gauge steamer owned by thousands of boys in the early twentieth century: wildly oversized drivers, bright brass or nickel trim, colorful, gleaming paint, and a cast iron frame topped by a sheet metal boiler and cab. Our Tinplate Traditions 384 Christmas set replicates the starter sets that gladdened the heart of many a child on a holiday or birthday in the early 1930s - with one exception.

Thanks to Proto-Sound 2.0 electronics, our 384 steamer delivers smoother operation than any original standard gauge locomotive, as well as huge plumes of puffing smoke - timed to the driver's revolutions - and a clanging bell and wailing whistle that are sure to add cheer to your holidays. Our replica of the 384 is trailed by two passenger cars decorated for Christmas with bright metal trim and colorful baked enamel paint.



No. 384 Standard Gauge Passenger Set



TINPLATE TRADITIONS
By MTH Electric Trains

Standard gauge steam engines like the 384 were not so much scale models of real locomotives, but cartoon-like caricatures: wildly oversized drivers, bright brass or nickel trim, colorful, gleaming paint, and a cast iron frame topped by a sheet metal boiler and cab. Our Tinplate Traditions Baltimore & Ohio passenger set replicates the magic of the tinplate trains that gladdened the heart of many a child in the early decades of the 20th century.

The bright colors of this set are inspired by B&O name trains like the Capitol Limited and the Cincinnati, that, as the B&O proclaimed, "linked 13 great states with the nation." Thanks to Proto-Sound® 2.0 electronics, our 384 steamer delivers smoother operation than any original standard gauge locomotive, as well as huge plumes of puffing smoke - timed to the driver's revolutions - and a clanging bell and wailing whistle guaranteed to delight children of all ages. Our replica of the 384 is trailed by two B&O passenger cars decorated with bright metal trim and colorful baked enamel paint.



Today M.T.H. is the only company in the world offering a full line of Standard Gauge and O Gauge tinplate trains, track, and accessories that faithfully duplicate the magic of the pre-war tinplate era. See our latest Tinplate Traditions catalog online at www.mthtrains.com.

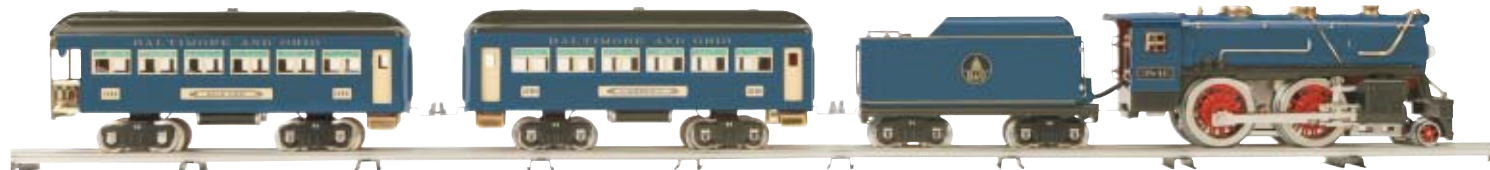

Baltimore & Ohio - No. 384 Steam Passenger Set
10-1294-1 w/Proto-Sound® 2.0 \$599.95



Baltimore & Ohio - 330 Series Passenger Car
10-5092 \$149.95



Baltimore & Ohio - 330 Series Baggage Car
10-5091 \$149.95



Baltimore & Ohio - 500 Series Std. Gauge Reefer Car
10-2225 \$99.95

192 Villa Set
10-4072 \$199.95



#191 Villa
10-4073 \$69.95

Rugged - Realistic - Reliable

At M.T.H. we believe a track system should allow your model railroad empire to grow. The RealTrax system includes 72 different components for maximum expansion capabilities. You'll find bridges, curves of all sizes, elevated and graduated trestles, crossovers, and every straight and curved configuration you'll need to create your own model railroad empire. And every piece of RailTrax is rugged, realistic, and reliable so you can have fun running your trains.

Rugged

Because most toy train empires begin on a carpet or floor, RealTrax is designed to hold up to the rigors of childhood play. Strong snap-together connections make it easy to assemble or change a layout in minutes. And the built-in roadbed helps keep dirt on the floor away from the wheels and gears of your trains.



Realistic

With its realistic cross-ties and ballasted roadbed, RealTrax looks like the mainline track used by heavy freights and high-speed passenger trains. Unlike older O gauge track with a round cross section, RealTrax uses flat-top "T"-rail like a real railroad.

Reliable

Nickel silver rail ensures that RealTrax will never rust. Spring-loaded phosphor bronze contacts provide superior electrical connections between track sections. The contacts are spring loaded to maintain a solid connection over time and are highly resistant to corrosion of any kind. Similar materials are used in many electrical connections around your home, such as lamps, battery-operated appliances, and electrical outlets.



RealTrax switches feature the same durable construction as regular RealTrax sections and utilize long-lasting switch motors that provide precise throws every time. The reversible motor mechanism quickly snaps onto the other side of the switch if space is a problem. No disassembly of the switch is required! Lighted switch controllers allow you to throw a switch remotely from a distance, and lights on the controller indicate which direction the switch is thrown - green for straight and red for curved.

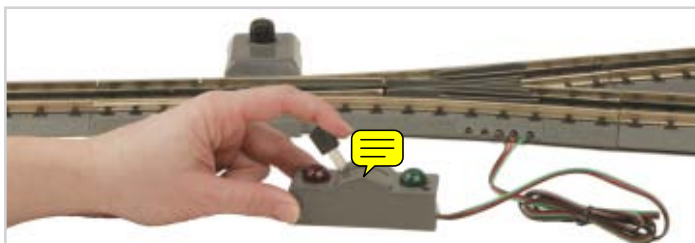

REALTRAX
BY M.T.H. ELECTRIC TRAINS

IT TAKES **EIGHT O-31 CURVES** TO MAKE A CIRCLE.
IT TAKES **TWELVE O-42 CURVES** TO MAKE A CIRCLE.
IT TAKES **TWELVE O-54 CURVES** TO MAKE A CIRCLE.
IT TAKES **SIXTEEN O-72 CURVES** TO MAKE A CIRCLE.
IT TAKES **SIXTEEN O-82 CURVES** TO MAKE A CIRCLE.

RealTrax 3.5" Track Section 40-1018 \$3.50	RealTrax 4.25" Track Section 40-1017 \$3.50
RealTrax 5.0" Track Section 40-1016 \$3.50	RealTrax 5.5" Track Section 40-1012 \$3.50
RealTrax 10" Straight Track Section 40-1001 \$3.99	
RealTrax - 10" Ground Track (2 pieces per pack) 40-1068-2 \$7.99	

Crossover & Operating Sections

RealTrax - 90* Crossover Track 40-1006 \$19.95	RealTrax - 45* Crossover Track 40-1007 \$19.95
RealTrax - Operating Track Section 40-1008 \$29.95	

RealTrax - Adapter Track Section 40-1011 \$7.99	RealTrax - 10" Insulated Straight Track Section Set 40-1029 \$7.99		
RealTrax - 30" Straight Track Section 40-1019 \$10.99			
RealTrax O-31 Half Curve Track 40-1022 \$3.50	RealTrax O-42 Half Curve Track 40-1045 \$3.99	RealTrax O-54 Half Curve Track 40-1057 \$4.99	RealTrax O-72 Half Curved Track Section 40-1049 \$4.99
RealTrax O-31 Curved Track Section 40-1002 \$3.99	RealTrax O-42 Curved Track Section 40-1042 \$3.99	RealTrax - O-54 Curved Track Section 40-1054 \$4.99	
RealTrax - O-72 Curved Track Section 40-1010 \$4.99		RealTrax - O-82 Curved Track Section 40-1082 \$5.99	
RealTrax - O-31 Switch (RH) 40-1004 \$59.95	RealTrax - O-31 Switch (LH) 40-1005 \$59.95	RealTrax - O-42 Switch (RH) 40-1043 \$64.95	RealTrax - O-42 Switch (LH) 40-1044 \$64.95
RealTrax - O-54 Switch (R) 40-1055 \$69.95	RealTrax - O-54 Switch (L) 40-1056 \$69.95	RealTrax - O-72 Switch (RH) 40-1020 \$79.95	RealTrax - O-72 Switch (LH) 40-1021 \$79.95
			RealTrax - O-72 Wye Switch 40-1068 \$79.95



RealTrax - 8-Piece Elevated Trestle System
40-1034 \$19.95

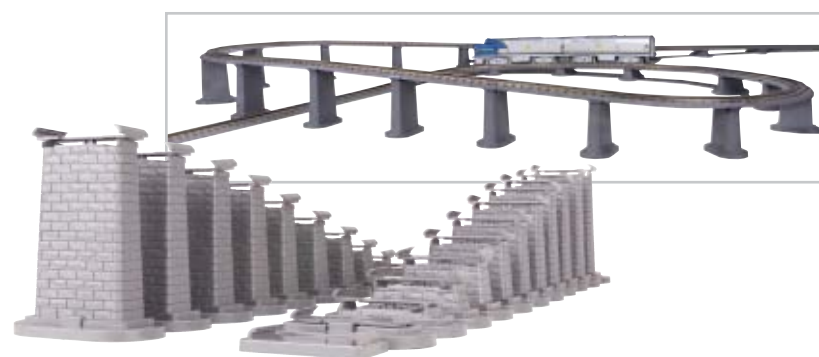

RealTrax - 24-Piece Graduated Trestle System
40-1033 \$29.95



RealTrax - 8-Piece Catenary System
40-1035 \$149.95

RealTrax - 4-Piece Add-On Catenary System
40-1036 \$79.95

RealTrax - Catenary Hardware Pack
40-1039 \$19.95

Catenary Features:

- Compatible with RealTrax® or any other O-Gauge Track
- Removable RealTrax® Lock-On Base Connection
- Thumbscrew Power Terminals
- Adjustable Pole Spacing
- Adjustable Messenger Beam Height
- Adjustable Wire Positioning
- Base Mounting Screws Included



RealTrax - Non-Slip Track Pads (50/pack)
40-1046 \$7.95

RealTrax - Track Clips (24)
40-1041 \$7.95

RealTrax - Lighted Lockon
40-1003 \$4.99

RealTrax - Track Activation Device (I.T.A.D.)
40-1028 \$19.95



RealTrax - Lighted Bumper
40-1024 \$12.95

Layout Builders

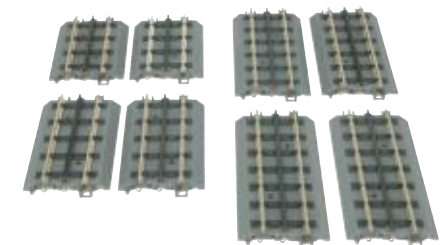

RealTrax - Layout Builder (8 Pcs)
40-1023 \$24.95
(Contains: (2) 3.5" Half Tracks, (2) 4.25" Half Tracks, (2) 5.0" Half Tracks, (2) 5.5" Half)



RealTrax - Right Hand Track Siding Layout Builder
40-1027 \$84.95
(Contains (1) Right-Hand O-31 Switch, (4) 10" Straights, (1) O-31 Curve, (1) RealTrax™ Bumper)

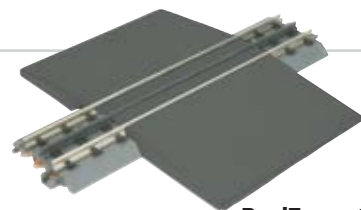

RealTrax - Grade Crossing
40-1009 \$9.95

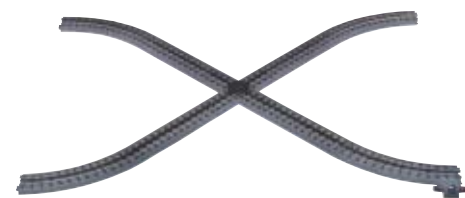

RealTrax - Figure 8 Layout Builder
40-1025 \$49.95
(Contains: (4) O-31 Curves, (4) 10" Straights, (1) Lighted Lockon, (1) 90 Degree Crossover)



RealTrax - Left Hand Track Siding Layout Builder
40-1026 \$84.95
(Contains (1) Left-Hand O-31 Switch, (4) 10" Straights, (1) O-31 Curve, (1) RealTrax Bumper)



RealTrax - O-72 Wye Switch Spur Layout Builder
40-1069 \$134.95
(Contains (1) O-72 Wye Switch, (6) 10" Straight Track Sections, (2) RealTrax Lighted Bumpers, (2) O-72 Half Curve Track Sections)



O Bridge Girder - Rust
40-1032 \$19.95
O Bridge Girder - Silver
40-1014 \$19.95



O Steel Arch Bridge - Rust
40-1031 \$59.95
O Steel Arch Bridge - Silver
40-1013 \$59.95



O 2-Track Steel Arch Bridge - Rust
40-1058 \$89.95
O 2-Track Steel Arch Bridge - Silver
40-1062 \$89.95



O 2-Track Bridge Girder - Rust
40-1059 \$29.95
O 2-Track Bridge Girder - Silver
40-1063 \$29.95

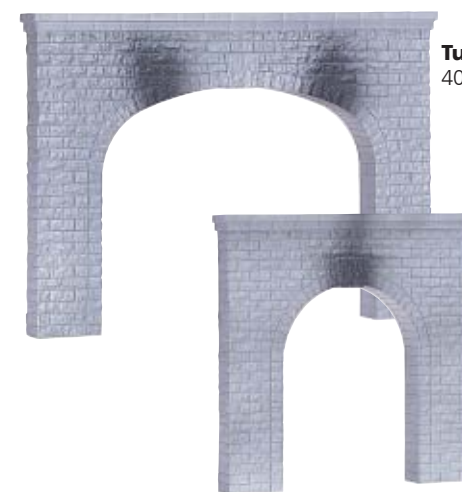

Tunnel Portal - Double
40-9015 \$19.95

Tunnel Portal - Single
40-9014 \$14.95

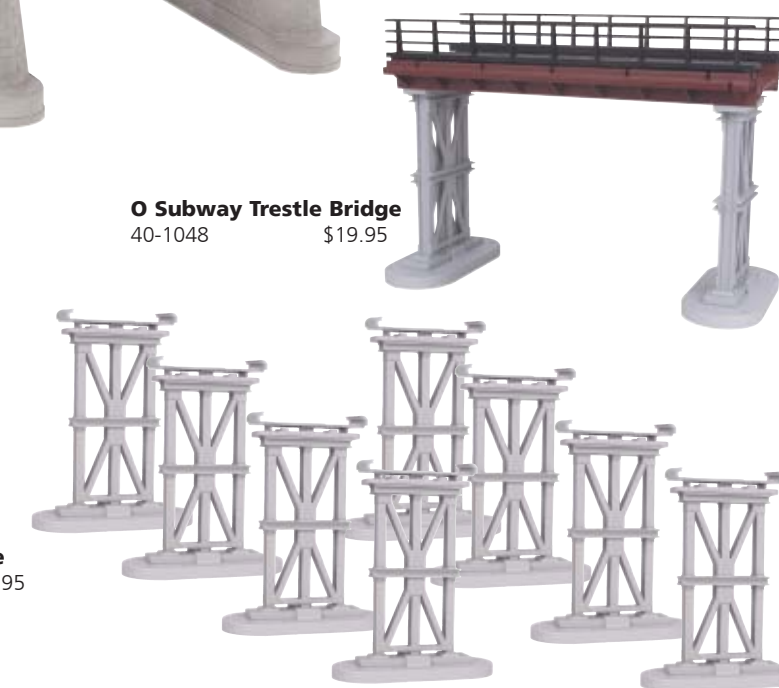

O Subway Trestle Bridge
40-1048 \$19.95

Over & Under Tunnel
40-1070 \$59.95



**FULLY SCENED,
READY TO USE!**

TRACK, TRAIN & TRESTLES NOT INCLUDED

8 Piece Elevated Subway Trestle Set
40-1047 \$19.95

Tinplate Track & Accessories

Transformers



Std. Gauge Track - 36" Reg. Straight
10-1036 \$6.99



Std. Gauge Track - 36" Extra Ties Straight
10-1045 \$7.99



Std. Gauge Track - Straight w/Extra Ties
10-1040 \$4.49



Std. Gauge Track - Reg. Straight
10-1038 \$3.99



Std. Gauge Track - 42" Dia. Reg. Curved
10-1039 \$3.99

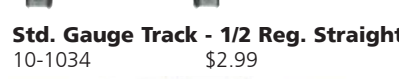

Std. Gauge Track - 1/2 Reg. Straight
10-1034 \$2.99

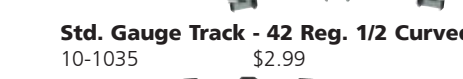

Std. Gauge Track - 42 Reg. 1/2 Curved
10-1035 \$2.99



Std. Gauge Track - 72" Dia. Wide Radius Curve
10-1041 \$4.49



Std. Gauge Track - 84" Dia. Curved
10-4020 \$4.99



Green/Cream/Maroon - AF Std. Gauge Switch Tower
10-4053 \$299.95

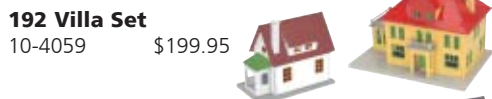

192 Villa Set
10-4059 \$199.95



Ives #1868 Villa
10-4060 \$69.95



Red & Silver - No. 55 Airplane & No. 49 Airport Set w/Mat
10-4017 \$799.95

The standard gauge track on this page has rails spaced 2 1/8" apart, while the O gauge track pictured elsewhere in this catalog has a gauge of 1 1/4".

IT TAKES **TWELVE 42" CURVES** TO MAKE A CIRCLE.
IT TAKES **SIXTEEN 72" CURVES** TO MAKE A CIRCLE.
IT TAKES **SIXTEEN 82" CURVES** TO MAKE A CIRCLE.

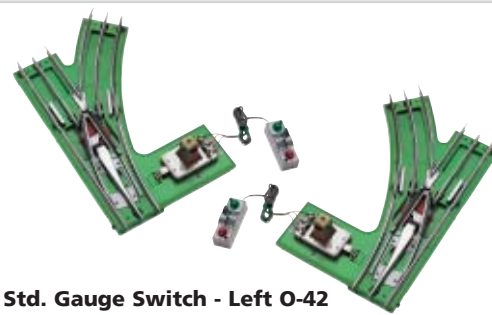

Std. Gauge Switch - Left O-42
10-4002 \$79.95

Std. Gauge Switch - Right O-42
10-4001 \$79.95

Std. Gauge Switch (Wide Radius) - Left O-72
10-4004 \$89.95

Std. Gauge Switch (Wide Radius) - Right O-72
10-4003 \$89.95

Std. Gauge Switch - Right Hand 42 (Black Base)
10-4101 \$79.95

Std. Gauge Switch - Left Hand 42 (Black Base)
10-4102 \$79.95

Wire Harness
10-1020 \$3.99



O/Std. Gauge Lighted Lockon
10-1021 \$3.99



Aluminum - #63 Lamp Post Set
10-1108 \$39.95



Track Activation Device (TAD)
10-1037 \$9.95

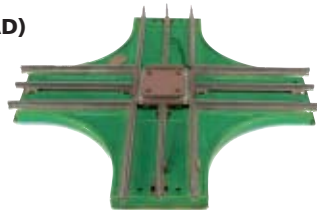
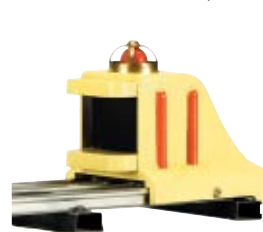

Std. Gauge 90* Crossover
10-4006 \$49.95

Std. Gauge Track Bumpers
10-4005 \$49.95



Z-750™ Transformer
40-750 \$79.95



Z-1000™ Transformer
40-1000 \$99.95
With 14 Volt Accessory Port

400 Watts!
The Most Powerful
U.L. Listed
Transformer!



Z-4000™ Transformer
40-4000 \$429.95



RealTrax® Wire Harness
40-1015 \$4.99



100-Watt Accessory Power Supply
40-1000A \$79.95

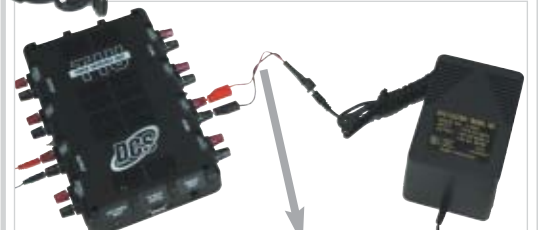

TIU/Barrel Jack Adapter Cable
50-1017 \$9.95

While the power pack that comes with every RailKing® Ready-To-Run set provides plenty of power to operate your set & several additional cars, you'll find as you add more track, cars, & accessories to your layout that you need more power to keep everything running. Fortunately, RailKing has you covered.

If you want to power up gradually, you can purchase additional 75-watt Z-750 or 100 watt Z-1000 transformers as the need arises. Featuring a U.L. approved design, each model utilizes a separate controller which contains bell, horn & direction buttons that can control any manufacturer's locomotives & sound systems including Proto-Sound® equipped steam, diesel & electric locomotives.

If you want to max out your power potential, the 400-watt Z-4000 is the most powerful transformer to receive the UL-listing for the model railroading hobby. The Z-4000 has two separate throttles to let you power two different tracks, & it has two fixed power outputs you can use for operating accessories. A single Z-4000 will power a lot of layout.

DCS™ users who don't need a conventional transformer and controller can use this 100 watt power supply for small and moderate sized layouts. Featuring a U.L. approved design & separate 14v AC Accessory Port, its robust design will provide years of service. Use the optional TIU/Barrel Jack adapter to make connecting it to the DCS Track Interface Unit quick and easy.

WHY THE U.L. LISTING?
M.T.H. Electric Trains is committed to manufacturing safe, U.L. approved transformers and power supplies. By subjecting our transformers to the strenuous tests and requirements of the U.L. laboratories, M.T.H. helps ensure that these products meet the same requirements as other consumer electronics sold today. When choosing a new transformer, model railroaders should only look for those that have received a U.L. listing.

SIMPLY THE BEST WAY TO RUN A RAILROAD

There is a new way of controlling model railroads today that you've got to see to believe. It's called DCS (for Digital Command System) and it's the most revolutionary product to hit model railroading since locomotives first became equipped with sound!

Unlike traditional or conventional means of operating a model railroad, command systems allow the user to independently control each engine even if other engines are on the same track at the same time. The concept has been around since the early 1990's, but only DCS makes it simple and easy to use — thanks to its state-of-the-art technology and intuitive interface.

Upgrading to DCS unlocks more features than you'll find in any other command control operating system — features that are factory-installed in every Proto-Sound® 2.0 train set locomotive. Here's just a partial list of what DCS offers:

WIRELESS HANDHELD THROTTLE

Run your whole railroad — locomotives, accessories, everything — from one or more DCS handheld remotes. An LCD screen indicates which engine you're controlling and its current speed, adjustable in one-scale-mile-per-hour increments. Program engines and accessories on the same screen. For nighttime operation, turn on the screen's backlight.

COMMAND CONTROL

Operate up to 99 DCS-equipped engines independently at the same time on the same electrically continuous track — using one or several DCS wireless handheld remotes. When you have guests, give each visitor a DCS handheld and let them control their own engine. Just like the prototype, you can double-head locomotives, add or drop helper engines, or bring a train into the station with a mainline engine and then have a switcher break up the consist.

PROTO-SOUND 2.0 ENGINE SOUNDS

DCS offers individual control of dozens of sounds built into every M.T.H. locomotive. Rev the diesel motor up manually before moving your train. Activate auxiliary sounds such as steam letoff and crew conversations. Whistle, bell, and steam chuff or diesel prime mover sounds even have independently adjustable volume control.

TRAIN SOUNDS

Add ambience to your railroad with the variety of train sounds built into Proto-Sound 2.0. The DCS handheld gives you access to effects such as wheel clickety-clack, coupler opening sounds, and the Doppler effect of a train passing by. DCS also offers one-button activation of the Passenger Station or Freight Yard Proto-Effects™ built into every Proto-Sound 2.0 locomotive.

SMOKE CONTROL

Adjust the smoke intensity for a steam or diesel engine at any time from the DCS remote.

CONSTANT LIGHTING

Because DCS operates with a constant voltage on the rails (most operators use 18 volts), engine, caboose, and passenger car lights are always on at a constant intensity. No more "lights-out" when a passenger train arrives at a station!

PROGRAMMABLE OPERATION

Record up to 90 minutes of DCS speed, direction, and sound commands as a program that your engines can repeat on demand. Use this feature to run trains automatically on one part of your railroad while you manually control another area.

UPGRADABLE SOFTWARE

Unlike any DCC or any other command system, DCS is designed to be upgradable over the Internet. The latest software can be downloaded to any DCS system ever made, so new features can be added and your investment will not become obsolete.

TMCC® COMPATIBILITY

Add a Lionel® Command Base to your DCS system and you can run engines equipped with TMCC® (Lionel's TrainMaster® Command Control) side-by-side with DCS engines - all from the DCS handheld controller. If you prefer, you can even use a Lionel CAB-1® handheld to control TMCC engines at the same time you're controlling Proto-Sound engines with the DCS controller.

LISTEN TO YOUR FAVORITE TUNES WITH PROTO-CAST™

DCS is the only command control system that lets you hook up any audio source and play your favorite music right through the train!

BE YOUR OWN DISPATCHER

With DCS's built-in remote microphone, real-time radio dispatch calls are just a button push away.

COMMAND CONTROL EXPLAINED

In conventional operation, an AC or DC transformer varies track current to adjust engine speed and direction. Command systems such as DCS™, however, put a constant voltage on the track (around 18 volts for DCS) and vary speed by telling each engine how much of that voltage to use. Command control allows different engines to do different things - like run at different speeds, go in different directions, or make different sounds - even when they are on the same track.

In the DCS system, commands such as speed, direction, and sound control are sent as radio signals from the handheld throttle to a TIU (track interface unit). The TIU translates those radio signals into digital information that is sent through the rails and picked up by a receiver in the appropriate engine - telling it to go, for example, 37 miles per hour, blow the whistle, smoke more heavily, or any other command. DCS locomotives can also send information back to the handheld to let the operator know what they're doing.

INTUITIVE MENUS ALLOW YOU TO PROGRAM, SELECT, AND CONTROL ENGINES, SWITCHES, AND ACCESSORIES.

1 ► ADD ENGINE
EDIT ENGINE
DELETE ENGINE
MENU:ENGINE SETUP

Go to the engine set up menu

2 ► ADD MTH ENGINE
ADD TMCC ENGINE
MENU:ADD ENGINE

Choose your engine type

3 CONGRATULATIONS
YOU SUCCESSFULLY
ADDED AN MTH ENGINE

SMPH: 10
1: FRR S1
MTC SCS S01 LIN →

DCS will "look" for Proto-Sound® or TMCC command-equipped engines on your layout. When it finds one, it adds it onto your remote and tells you when it's done.

*TMCC operation requires a TMCC command base & DCS TIU/TMCC cable



EVERY PROTO-SOUND 2.0 TRAIN SET LOCOMOTIVE IS ALREADY EQUIPPED TO RUN ON DCS

DCS COMPONENTS

<p>DCS Remote Control System 50-1001 \$299.95</p>	<p>DCS Remote Control - Handheld Unit 50-1002 \$149.95</p>
<p>DCS Accessory Interface Unit (AIU) 50-1004 \$99.95</p>	<p>DCS Track Interface Unit (TIU) 50-1003 \$179.95</p>

<p>Proto-Sound Battery 50-1008 \$9.95</p>	<p>AA NiCad Proto-Sound Battery 50-1024 \$9.95</p>
<p>Proto-Sound 2.0 Battery Charger 50-1019 \$14.95</p>	<p>TIU/TMCC 6' Connector Cable 50-1018 \$19.95</p>
<p>6' Mini-to-Mini Cable 50-1009 \$9.95</p>	<p>TIU/Barrel Jack Adapter Cable 50-1017 \$9.95</p>
<p>24-Port Terminal Block 50-1020 \$29.95</p>	<p>12-Port Terminal Block 50-1014 \$19.95</p>
<p>Video Guide To DCS - DVD 60-1191 \$19.95</p>	<p>Video Guide To DCS - VHS 60-1190 \$19.95</p>

B/L - Screen backlight on/off

AUX - Auxiliary menu

ACC - Accessory menu

BELL - Rings bell

ENG - Engine menu (to select and control engines)

MENU - Access 4 main menus: Sound, Control, System, Advanced

LABOR/REV UP OR DRIFT/REV DN - Makes an engine sound like it's working harder or easier

BOOST/BRAKE - Temporarily Raises or Lowers Speed

SMOKE - Turns smoke unit on & off

VOL+ - Globally increases all sounds

ENG SND - Silences engine sounds

VOL- - Globally decreases all sounds

HDLT - Turns headlights on & off

PROTOCAST - Activates Proto-Cast™

READ - Search for TIUs, AIUs and Proto-Sound® 2.0 Engines on the track

MICROPHONE

LCD DISPLAY

SOFTKEYS - Activate locomotive features

MIC - Turns Proto-Dispatch™ on & off

TR - Track menu (Access various tracks/blocks on your layout)

SW - Switch menu

W/H - Blows whistle/horn

THUMBWHEEL - Throttle & selection (scroll & press) tool

DIR - Changes locomotive direction

CPLR-F/CPLR-R - Fires front & rear couplers

START UP - Activates sound, smoke & lights

SHUT DOWN - Deactivates all sound, smoke & lights

PFA - Activates Passenger/Freight Sounds

E-STOP - Cuts power to all tracks

DOPPLER - Activates Proto-Doppler™

Programming Port - Tether attaches between remote and TIU for programming new software features

Accessories

OPERATING TRANSFER DOCK

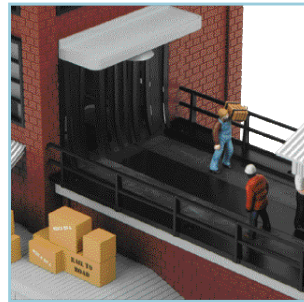

Moving freight is what most of today's railroading is all about. The new MTH RailKing® Transfer Dock is the perfect accessory to showcase your layout's freight activity.

This attractively detailed, ABS structure features a truck loading dock and elevated rail platform perfect for simulating freight movement between tractor trailer and rail car. There's lots of activity on this dock thanks to the moving dock workers who tirelessly hand truck their freight from platform to warehouse. Featuring near-silent operation and realistic movement, this fully functioning accessory comes completely assembled, painted and decorated for right-out-of-the-box use.

Operating Transfer Dock

30-9110 \$149.95
Measures: 18 7/8" x 10 3/16" x 9 3/4"

- FEATURES:**
- Intricately Detailed ABS Construction
 - Fully Assembled
 - Fully Painted
 - Lighted Interior
 - Operating Dock Workers Move Freight

OPERATING McDONALDS®

Recreate one of America's most popular modern-day restaurants with this unique and fun to operate accessory.

Fully assembled and painted, the accessory hooks up in minutes to any AC transformer. Activation occurs with just a touch of a button at which point the included SUV begins circling the structure stopping first to place an order and then a second time to pickup the food. Audio features include the sounds of different customers ordering for a sense of variety and background car radio music for an added touch of realism.

- FEATURES:**
- ABS Construction
 - Fully Assembled & Painted
 - Interior Illumination
 - Automatic Operation & Digital Sound Effects
 - Die-Cast 1/43 Scale SUV Included



Operating McDonalds®
30-9114 \$149.95
Measures: 17" x 17" x 7 3/4"



As a siren wails and lights flash, watch the fireman slide down the pole, the engine house door open, and the fire truck race off to the fire!

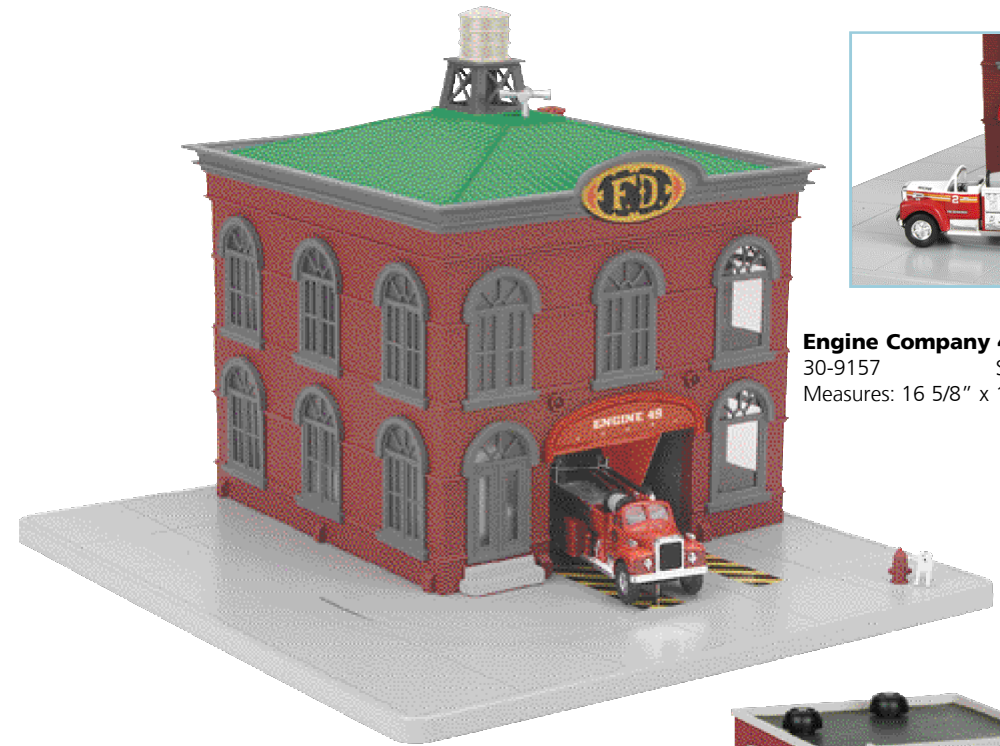

Engine Company 49 - Operating Firehouse
30-9157 \$149.95
Measures: 16 5/8" x 15 3/8" x 12 3/8"



White w/Blue Shutters - House On Fire
30-9153 \$129.95
Measures: 7 1/2" x 7 1/2" x 7"



Red/Black - 3-Story Town House On Fire
30-9155 \$129.95
Measures: 6 3/8" x 3 15/16" x 7 1/8"

OPERATING SHELL STATION

Shell - Operating Gas Station
30-9133 \$149.95
Measures: 15" x 11" x 6 3/4"



- TRADITIONAL ACCESSORIES
- MISCELLANEOUS ACCESSORIES
- O SCALE ACCESSORIES

Accessories

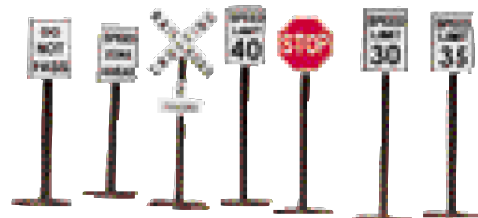

Road Sign Set (2 Each)
30-1087 \$14.95
Measures: 2" Tall

O Scale Water Column
30-11007 \$29.95
Measures: 4" Tall

Operating Traffic Light Set Single Lamp
30-1089-1 \$19.95
Measures: 5" Tall

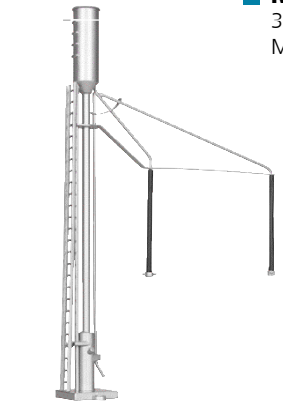

Sanding Tower
30-11040 \$29.95
Measures: 1 3/16" x 1 1/4" x 10 3/8"

O Scale Tell Tale
30-11026 \$19.95
Measures: 8" x 3"

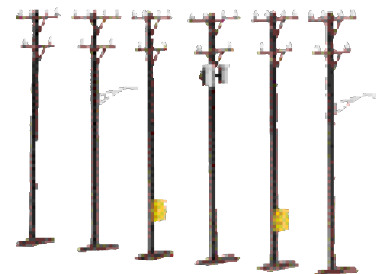

Telephone Pole Set
30-1088 \$14.95
Measures: 5 3/4" Tall



Fuel/Water Column Set
30-11037 \$29.95
Measures: 1 1/16" x 1 3/8" x 5 3/4"

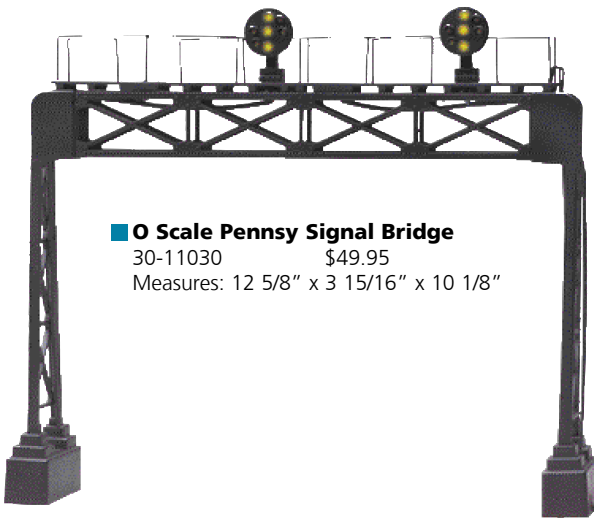

O Scale Pennsy Signal Bridge
30-11030 \$49.95
Measures: 12 5/8" x 3 15/16" x 10 1/8"



Black - "O" Lamp Set (Round)
30-1078 \$24.95
Measures: 4" Tall

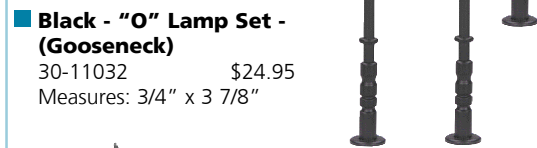

Black - "O" Lamp Set - (Gooseneck)
30-11032 \$24.95
Measures: 3/4" x 3 7/8"



Black - "O" Lamp Set - (Square)
30-1079 \$24.95
Measures: 4" Tall

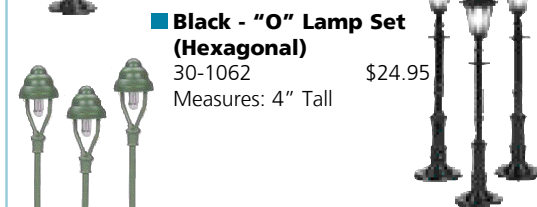

Black - "O" Lamp Set (Hexagonal)
30-1062 \$24.95
Measures: 4" Tall

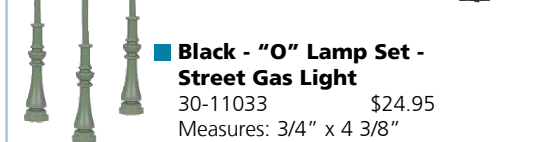

Black - "O" Lamp Set - Street Gas Light
30-11033 \$24.95
Measures: 3/4" x 4 3/8"

O Scale 3-Position Semaphore
30-11023 \$39.95
Measures: 7" Tall

O Scale 1 Over 1 Signal
30-11025 \$49.95
Measures: 7" Tall

O-Scale 2-Head Target Signal
30-11035 \$49.95
Measures: 7 3/8" Tall

O Scale 3 Over 3 Vertical Signal
30-11024 \$49.95
Measures: 6 3/4" Tall

O-Scale 7 Light Block Signal
30-11013 \$39.95
Measures: 7" x 1 1/2" x 2"

O-Scale Dwarf Signal
30-11011 \$24.95
Measures: 1" x 1 7/8" x 1 3/4"



6-Piece Barrel Set
30-50024 \$9.95

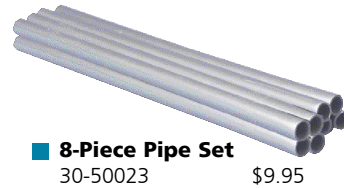

8-Piece Pipe Set
30-50023 \$9.95

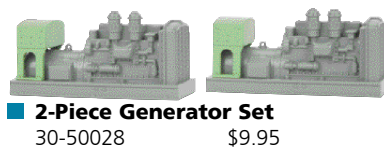

2-Piece Generator Set
30-50028 \$9.95



2-Piece Cement LCL Container Set
30-50029 \$14.95



2-Piece LCL Container Set
30-50030 \$14.95

O Scale Flashing Barricades (4)
30-11021 \$24.95
Measures: 1" x 1" x 2"

O Scale Pedestrian Crosswalk
30-9053 \$49.95
Measures: 11 5/8" x 13 3/8" x 7 7/8"

"O" Lamp Set - Triple Park Light
30-11034 \$39.95
Measures: 3/4" x 4 7/16"



O Scale Floodlight Tower Set
30-11039 \$69.95
Measures: 3" x 1 1/8" x 13 1/2"

"O" Lamp Set - Platform Light
30-11031 \$29.95
Measures: 3/4" x 4 3/8"



Red - #57 Corner Lamp Set
30-11080 \$24.95
Measures: 7 1/2" Tall

O Scale Cantilevered Signal Bridge
30-11009 \$49.95
Measures: 8 1/2" x 2 1/2" x 6 1/2"

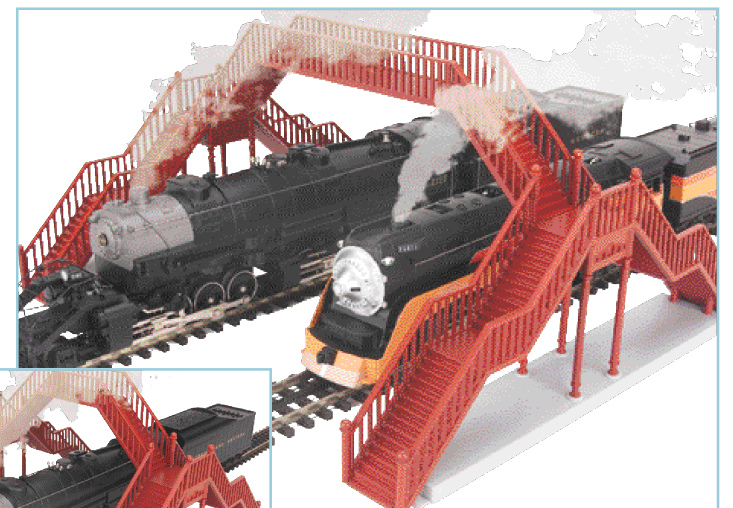

O Scale Pedestrian 2-Track Crosswalk
30-9066 \$59.95
Measures: 16 1/8" x 13 3/8" x 7 7/8"

Accessories



Fire Scene - 6-Piece Figure Set #8
30-11060 \$19.95



Miners - 6-Piece Figure Set #6
30-11058 \$19.95



Army - 6-Piece Figure Set #7
30-11059 \$19.95



Cops & Robbers - 6-Piece Figure Set #5
30-11056 \$19.95



Assortment 3 - 6-Piece Figure Set
30-11073 \$19.95



Assortment #2 - 6-Piece Figure Set #12
30-11075 \$19.95



Fire House Employees - 6-Piece Figure Set #2
30-11046 \$19.95



Assortment 2 - 6-Piece Figure Set
30-11072 \$19.95



Assortment #1 - 6-Piece Figure Set #12
30-11074 \$19.95



Assortment 1 - 6-Piece Figure Set
30-11071 \$19.95



Christmas - 6-Piece Figure Set
30-11062 \$24.95



Assortment #2 - 6-Piece Figure Set #12
30-11075 \$19.95



Subway - 12-Piece Passenger Figure Set
30-11063 \$29.95



Railroad Workman - 12-Piece Figure Set #3
30-11066 \$29.95



Passenger #3 - 12-Piece Passenger Figure Set
30-11067 \$29.95

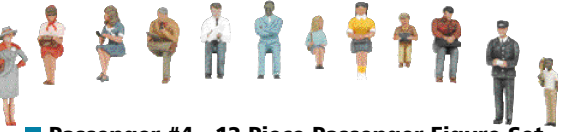

Passenger #4 - 12-Piece Passenger Figure Set
30-11068 \$29.95

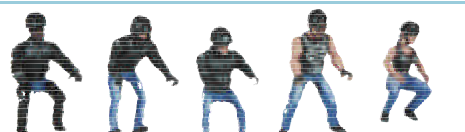

8-Piece Locomotive Cab Figure Set
30-11064 \$29.95



Harley-Davidson® 5-Piece Motorcycle Figure Set #1
30-11076 \$19.95



Roadster Hardtops - 32 Pack Vehicle Set
30-50031 \$159.95



Yellow - Die-Cast Fire Truck
30-50035 \$29.95
Measures: 6 1/4" x 2 1/8" x 1 7/8"



Red - Die-Cast Fire Truck
30-50034 \$29.95
Measures: 6 1/4" x 2 1/8" x 1 7/8"

120-Piece Passenger Figure Set
30-11043 \$29.95



Harley-Davidson® 4-Pack Motorcycle Set
30-90126 \$19.95
Measures: 2" Long x 1" High
Includes: (1) 2001 Dyna Low Rider®, (1) 2002 Fat Boy®, (1) 2002 1200cc Sportster®, (1) 2003 V-Rod®



Harley-Davidson® 4-Pack Motorcycle Set
30-11077 \$19.95
Measures: 2" Long x 1" High
Includes: (1) 2000 Dyna Super Glide®, (1) 2001 Springer Softail®, (1) 2001 Dyna Wide Glide®, (1) 2001 Road King®



© 2007 H-D, All Rights Reserved. Manufactured by M.T.H. Electric Trains under license from Harley-Davidson Motor Company.
© 2007 M.T.H. Electric Trains, 7020 Columbia Gateway Drive, Columbia, Maryland 21046



Pennsylvania Switch Tower
30-9031 \$49.95
Measures: 6 1/8" x 10 1/2" x 9"



Cream & Green- RailKing Hell Gate Bridge
30-9021 \$199.95
Measures: 34 1/2" x 15 1/4" x 15"



Operating O Scale Water Tower
30-11028 \$89.95
Measures: 7 1/2" x 11" x 10 1/4"



Conway Yards - O Scale Yard Master Tower
30-90167 \$54.95
Measures: 8 1/4" x 7 7/8" x 11 1/2"

Use the remote control buttons to pick up coal with the clamshell bucket and load it into the building. Then dump the coal into a waiting car below.

A perfect companion for any hopper car, or our operating dump cars on pages 14,23,27, and 31!

Operating Coaling Tower
30-9158 \$149.95
Measures: 9 1/2" x 8" x 12"



Dark Gray & Red - RailKing Hell Gate Bridge
30-90219 \$199.95
Measures: 34 1/2" x 15 1/4" x 15"

HOUSE NOT INCLUDED

White Fence Set
30-50002 \$9.95
Measures: 16" x 13"



Brown & Black - Elevated Gate Tower
30-9097 \$29.95
Measures: 3 1/2" x 2 1/2" x 5 3/4"



Union Pacific - Switch Tower
30-9048 \$49.95
Measures: 6 1/8" x 10 1/2" x 9"

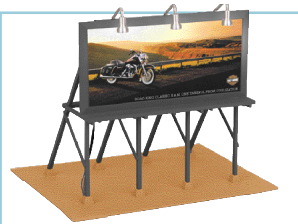

Harley-Davidson® Lighted Billboard
30-90212 \$29.95
Measures: 7 1/2" x 5 3/4" x 6"

HARLEY-DAVIDSON OFFICIAL LICENSED PRODUCT © 2007 H-D, All Rights Reserved. Manufactured by M.T.H. Electric Trains under license from Harley-Davidson Motor Company.
© 2007 M.T.H. Electric Trains, 7020 Columbia Gateway Drive, Columbia, Maryland 21046



DCS - Lighted Billboard
30-90041 \$29.95
Measures: 7 1/2" x 5 3/4" x 6"



Coors Light Lighted Billboard
30-90221 \$29.95
Measures: 7 1/2" x 5 3/4" x 6"

© 2007 Molson Coors Global Properties, LLC. Coors trademarks are properties of Molson Coors Global Properties, LLC, used under license by M.T.H. Electric Trains Limited Edition Adult Collectible-This licensed product is intended for purchase and enjoyment by individuals of legal purchase age for alcohol beverages.



Heinz - Lighted Billboard
30-90222 \$29.95
Measures: 7 1/2" x 5 3/4" x 6"
A licensed product of H.J. Heinz Company, L.P. © 2007



Budweiser - Lighted Billboard
30-90255 \$29.95
Measures: 7 1/2" x 5 3/4" x 6"
© 2007 Anheuser-Busch, Inc. All Rights Reserved.

Accessories



3-Rail Bettendorf Freight Car Two Truck Pack
30-89001 \$12.99

3-Rail Roller Bearing Freight Car Two Truck Pack
30-89002 \$12.99

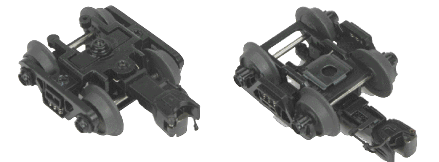

3-Rail Roller Bearing Freight Car Two Truck Pack
20-89004 \$12.99

3-Rail Bettendorf Freight Car Two Truck Pack
20-89003 \$12.99

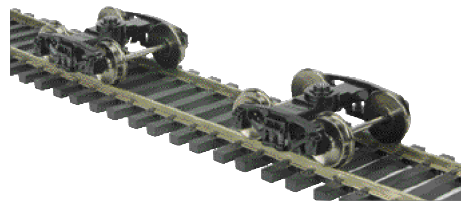

2-Rail Bettendorf Freight Car Two Truck Pack
20-89001 \$12.99

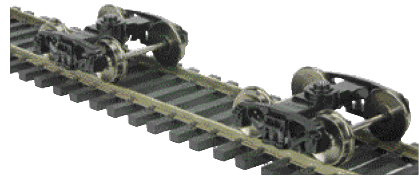

2-Rail Roller Bearing Freight Car Two Truck Pack
20-89002 \$12.99

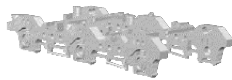

Proto-Scale 3-2™ 4-Wheel Truck Scale Wheel Set
20-89005 \$24.95

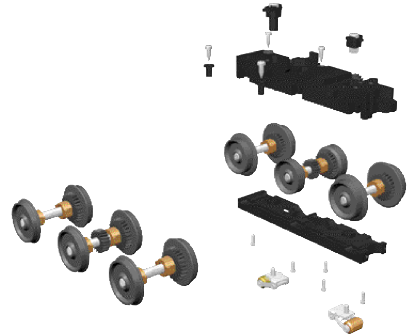

Proto-Scale 3-2™ 6-Wheel Truck Scale Wheel Set
20-89006 \$29.95



Bag Of Coal
30-50005 \$3.99



Track Cleaning Block
40-1099 \$17.99



Maintenance Kit
30-50010 \$14.95



8-Piece Log Set
30-50008 \$14.95

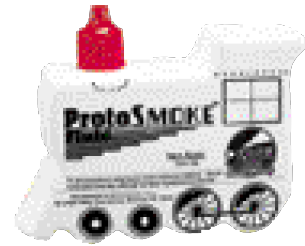

- ProtoSmoke™ Fluid (7oz.)**
- | | | |
|-------------|---------|---------|
| Unscented | 60-1045 | \$12.95 |
| Christmas | 60-1046 | \$12.95 |
| Coal | 60-1047 | \$12.95 |
| Diesel | 60-1048 | \$12.95 |
| Woodburning | 60-1049 | \$12.95 |

- ProtoSmoke™ Fluid (2 Oz.)**
- | | | |
|------------------------|-----------|----------|
| Assortment (36 pieces) | 60-1051 | \$179.95 |
| Christmas | 60-1051-a | \$4.99 |
| Coal | 60-1051-b | \$4.99 |
| Diesel | 60-1051-c | \$4.99 |
| Wood Burning (Hickory) | 60-1051-d | \$4.99 |
| Coffee | 60-1051-e | \$4.99 |
| Eggs & Bacon | 60-1051-f | \$4.99 |
| Vanilla | 60-1051-g | \$4.99 |
| Candy Cane | 60-1051-h | \$4.99 |
| Barbeque | 60-1051-i | \$4.99 |
| Pipe Smoke | 60-1051-j | \$4.99 |
| Cinnamon Roll | 60-1051-k | \$4.99 |
| Apple Pie | 60-1051-l | \$4.99 |



20' Container Set (3)
20-95063 \$29.95



40' Container Set (3)
20-95064 \$34.95



Trash Container (2)
30-50037 \$29.95

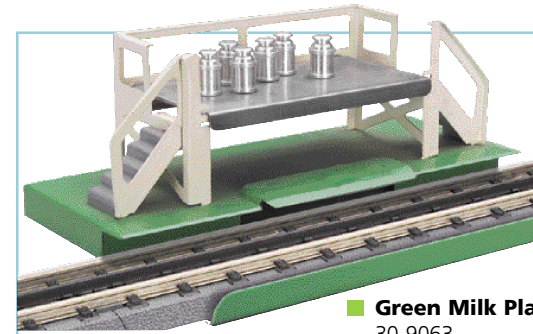

Green Milk Platform
30-9063 \$49.95
Measures: 7 1/8" x 5 7/8" x 2 1/2"

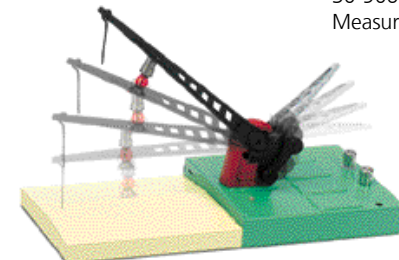

#46 Crossing Gate and Signal
30-11017 \$39.95
Measures: 16.5" x 3 1/2" x 5 3/4"



Pennsylvania - 314 Die-Cast Girder Bridge
30-12001 \$29.95
Measures: 10" x 4 1/2" x 1 3/4"



New York Central 314 Die-Cast Girder Bridge
30-12002 \$29.95
Measures: 10" x 4 1/2" x 1 3/4"

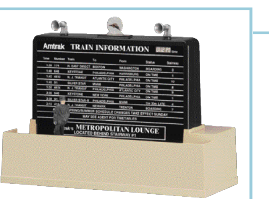

TIMETABLE AUTOMATICALLY FLIPS



#334 Dispatch Board
30-9022 \$99.95
Measures: 10 1/2" x 4 1/4" x 7 1/2"



Union Pacific - 314 Die-Cast Girder Bridge
30-12002 \$29.95
Measures: 10" x 4 1/2" x 1 3/4"



#262 Crossing Gate with Signal
30-1073 \$39.95
Measures: 9" Tall

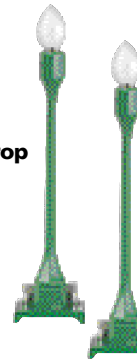

Pea Green #580-1 Teardrop Lamp Set
30-1079-A \$19.95
Measures: 6 3/4" Tall



Anheuser-Busch® - #193 Industrial Water Tower
30-90210 \$54.95
Measures: 6" x 6" x 14 3/4"

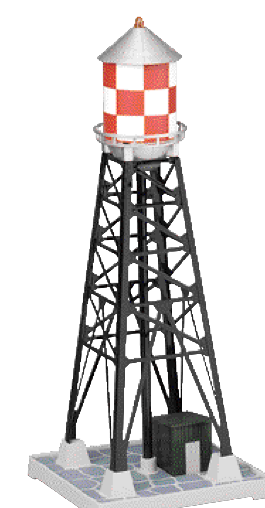

#193 Industrial Water Tower
30-9029 \$49.95
Measures: 6" x 6" x 14 3/4"



Harley-Davidson® - #193 Industrial Water Tower
30-90110 \$54.95
Measures: 6" x 6" x 14 3/4"

© 2007 Anheuser-Busch, Inc. All Rights Reserved.

HARLEY-DAVIDSON
© 2007 H-D. All Rights Reserved. Manufactured by M.T.H. Electric Trains under license from Harley-Davidson Motor Company.
© 2007 M.T.H. Electric Trains, 7020 Columbia Gateway Drive, Columbia, Maryland 21046



#151 Operating Semaphore
30-1075 \$29.95
Measures: 9 5/8" Tall

#153 Operating Block Signal
30-1076 \$29.95
Measures: 9 1/8" Tall



Operating Radar Tower
30-9032 \$39.95
Measures: 4 1/2" x 5" x 11 1/2"



Rotary Beacon
30-9033 \$49.95
Measures: 5" x 5" x 12"

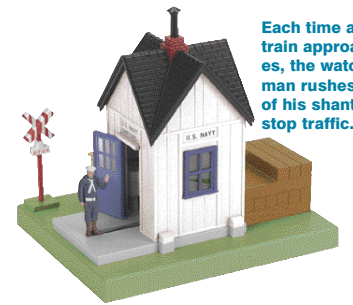

Navy Patrol - Operating Watchman's Shanty
30-9146 \$59.95
Measures: 4 1/2" x 5 15/16" x 4 1/8"

Each time a train approaches, the watchman rushes out of his shanty to stop traffic.

Accessories



Blue & White - Telephone Shanty
30-90002 \$12.95
Measures: 2" x 1 5/16" x 2 11/16"

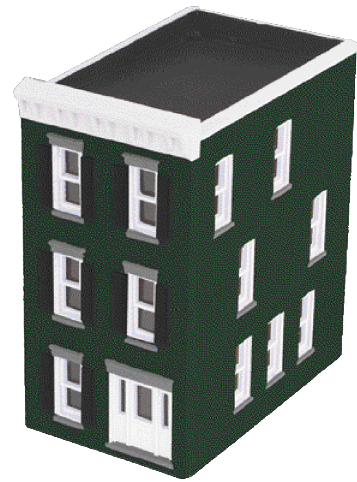

Dark Green & Black - 3-Story Town House #2
30-90238 \$34.95
Measures: 6 3/8" x 3 15/16" x 7 1/8"

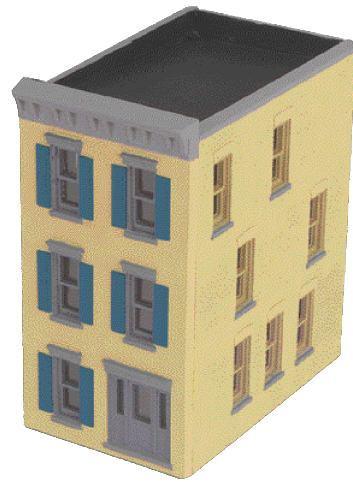

Blue & Yellow - 3-Story Town House #2
30-90240 \$34.95
Measures: 6 3/8" x 3 15/16" x 7 1/8"

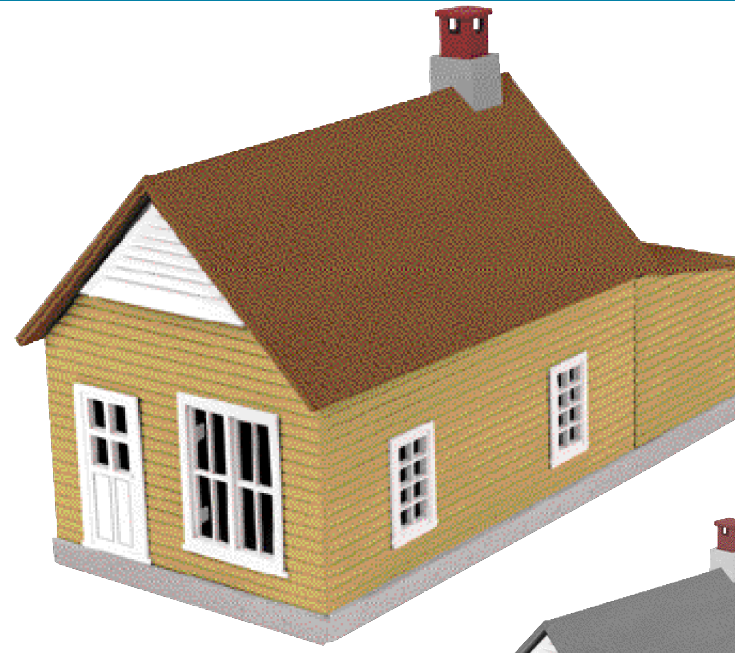

Mustard & Red - Work House #1
30-90008 \$29.95
Measures: 8 5/8" x 4 7/16" x 4 7/8"

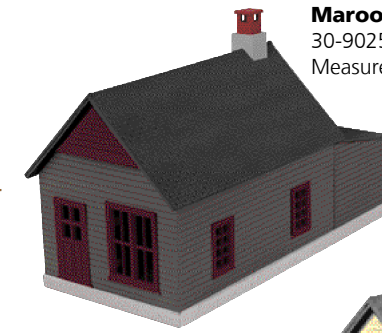

Maroon & Dark Gray - Work House #1
30-90250 \$29.95
Measures: 8 5/8" x 4 7/16" x 4 7/8"

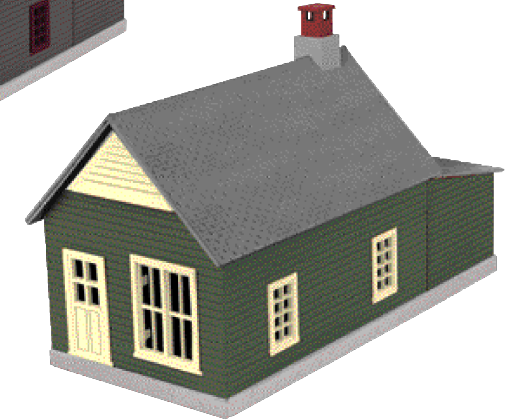

Green & Cream - Work House #1
30-90249 \$29.95
Measures: 8 5/8" x 4 7/16" x 4 7/8"



Gray & White - Out House
30-90001 \$12.95
Measures: 1 3/16" x 1 5/16" x 2 7/16"



FIGURE NOT INCLUDED
SEE MINER'S
SET PAGE 50



Red & Dark Blue - Row House #1
30-90247 \$29.95
Measures: 7 7/8" x 4 5/8" x 7"

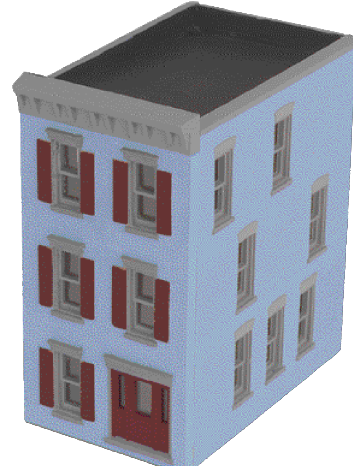

**Light Blue & Maroon
3-Story Town House #2**
30-90239 \$34.95
Measures: 6 3/8" x 3 15/16" x 7 1/8"

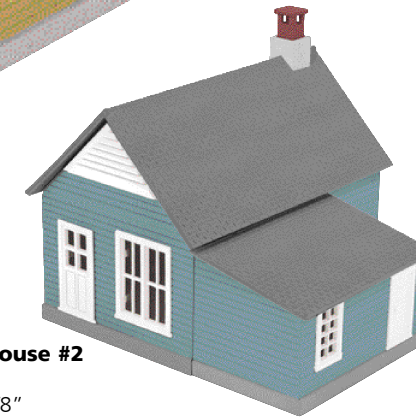

Light Blue & White - Work House #2
30-90252 \$29.95
Measures: 8 5/8" x 4 7/16" x 4 7/8"



Brown & Blue - Work House #2
30-90251 \$29.95
Measures: 8 5/8" x 4 7/16" x 4 7/8"



Blue w/Green Shutters - Country House #4
30-90241 \$34.95
Measures: 9 5/8" x 5" x 7"



Blue & Green - Row House #1
30-90248 \$29.95
Measures: 7 7/8" x 4 5/8" x 7"



Gray & Blue - Farm House #6
30-90254 \$34.95
Measures: 7 1/2" x 7 1/2" x 7"



Maroon & Yellow - Farm House #6
30-90253 \$34.95
Measures: 7 1/2" x 7 1/2" x 7"

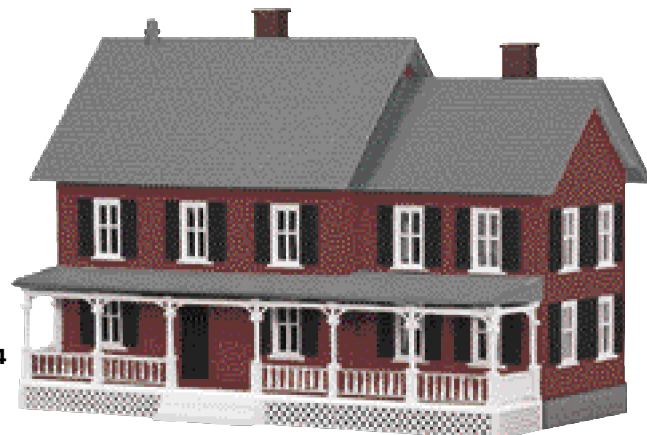

Maroon w/Black Shutters - Country House #4
30-90242 \$34.95
Measures: 9 5/8" x 5" x 7"

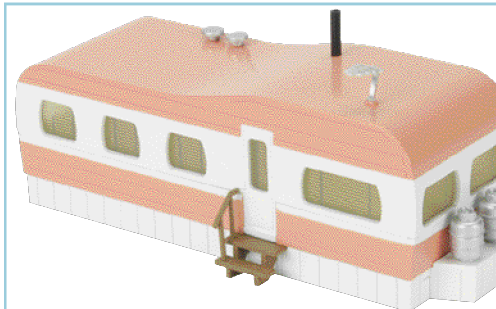

Salmon & White - Mobile Home
30-90109 \$29.95
Measures: 7 1/8" x 2 3/8" x 2 3/4"

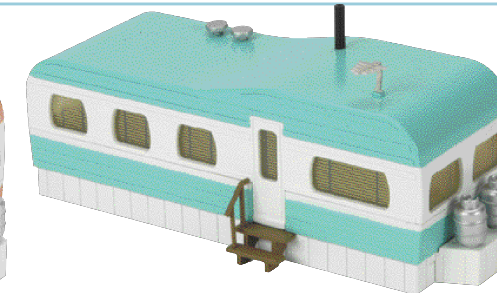

Turquoise & White - Mobile Home
30-90108 \$29.95
Measures: 7 1/8" x 2 3/8" x 2 3/4"

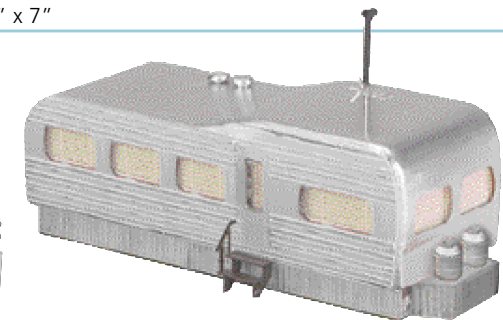

Stainless - Mobil Home
30-90005 \$29.95
Measures: 7 1/8" x 2 3/8" x 2 3/4"

Accessories

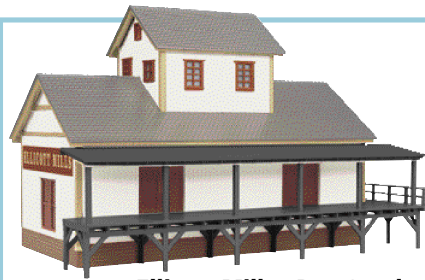

Ellicott Mills - Dry Goods Transfer Warehouse
30-90246 \$59.95
Measures: 13 1/2" x 8 1/4" x 9 1/8"

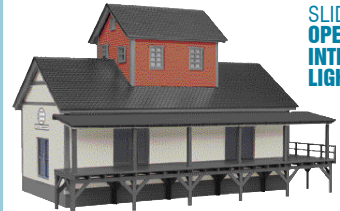

New York Central - Dry Goods Transfer Warehouse
30-90112 \$59.95
Measures: 13 1/2" x 8 1/4" x 9 1/8"

SLIDING DOORS & OPERATING INTERIOR LIGHTING



Orange - Yard Office
30-90013 \$39.95
Measures: 11" x 6 11/16" x 3 3/8"



Brown - Work Office
30-90012 \$39.95
Measures: 11 1/2" x 3" x 4"



Santa's Workshop
30-90256 \$34.95
Measures: 9 1/4" x 6 1/8" x 5"



Post Office
30-90257 \$34.95
Measures: 9 1/4" x 6 1/8" x 5"



Pennsylvania - Engine Shed
30-90083 \$99.95
Measures: 24" x 8 1/2" x 13 1/2"



Pennsylvania - Train Depot
30-90143 \$49.95
Measures: 11 1/2" x 7 3/4" x 4 3/4"



Tan - #5 Country Church
30-90187 \$29.95
Measures: 7 7/8" x 4 5/8" x 10 9/16"



Red & Black - Country Freight Station
30-90004 \$39.95
Measures: 9" x 5 1/2" x 5"

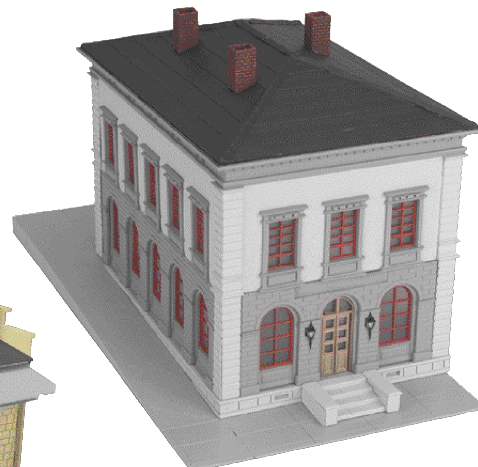

Gray & Black - Police Station
30-9099 \$59.95
Measures: 13 1/4" x 8 3/8" x 10"

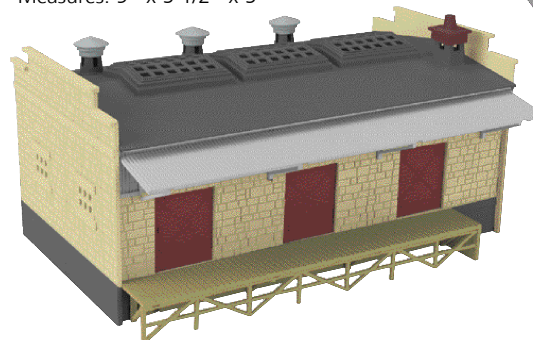

Beige & Black - Freight Transfer Warehouse
30-9098 \$69.95
Measures: 13 3/16" x 8 3/4" x 6 3/16"



Gray Stone - Grainery
30-90188 \$59.95
Measures: 10 1/4" x 7" x 11 1/8"



County Jail - Jail House
30-90014 \$29.95
Measures: 4 1/4" x 4 1/8" x 3 7/8"



Pennsylvania - Operating Station Platform
30-9152 \$49.95
Measures: 10" x 3 1/2" x 4"



PASSENGERS & FREIGHT "DISAPPEAR"

SEE IT OPERATE, VISIT WWW.MTHTRAINS.COM

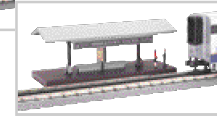

North Pole - Operating Freight Platform
30-9160 \$49.95
Measures: 10" x 3 1/2" x 4"



The Old Reading Brewing Company - Operating Freight Platform
30-90190 \$49.95
Measures: 9 3/4" x 3 1/2" x 3 3/4"

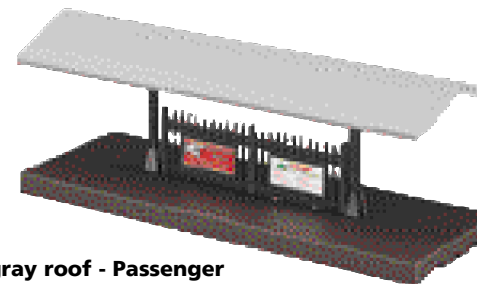

Brown w/gray roof - Passenger Station Platform
30-9006 \$19.95
Measures: 10" x 3 1/2" x 4"

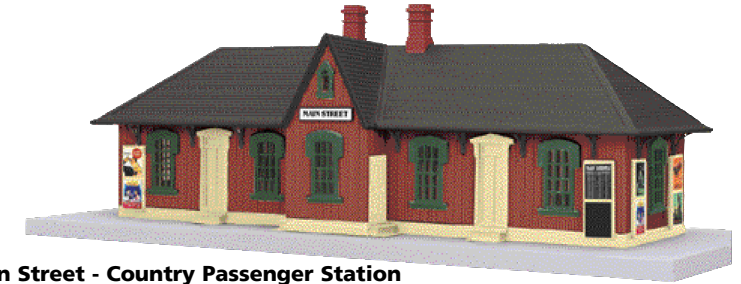

Main Street - Country Passenger Station
30-90081 \$49.95
Measures: 18 5/8" x 7 3/8" x 6 5/8"

ALL BUILDINGS FEATURE INTERIOR LIGHTING



North Pole - Country Passenger Station
30-90245 \$49.95
Measures: 18 5/8" x 7 3/8" x 6 5/8"



Elevated Station Platform
30-90027 \$29.95
Measures: 13 1/2" x 5 1/2" x 4"

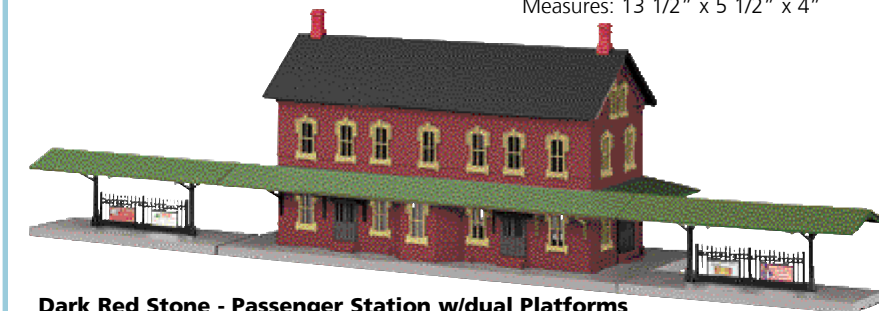

Dark Red Stone - Passenger Station w/dual Platforms
30-90094 \$79.95
Measures: 39" x 10 1/2" x 8 1/2"

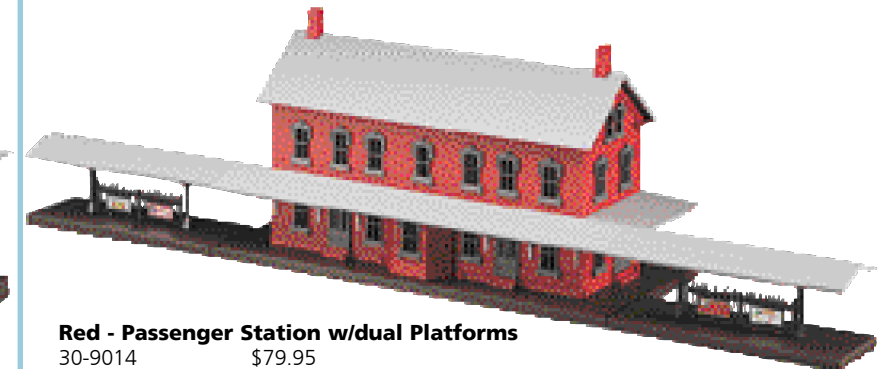

Red - Passenger Station w/dual Platforms
30-9014 \$79.95
Measures: 39" x 10 1/2" x 8 1/2"

Accessories



Harley-Davidson® - Motorcycle Dealership
30-90111 \$59.95
Measures: 9 3/8" x 9 3/8" x 6 3/8"

HARLEY-DAVIDSON
© 2007 H-D. All Rights Reserved. Manufactured by M.T.H. Electric Trains under license from Harley-Davidson Motor Company.
© 2007 M.T.H. Electric Trains, 7020 Columbia Gateway Drive, Columbia, Maryland 21046

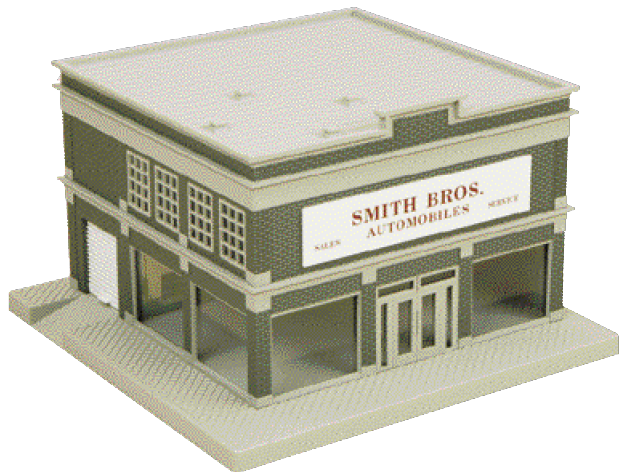

Smith Brothers - Automobile Dealership
30-90021 \$49.95
Measures: 9 3/8" x 9 3/8" x 6 3/8"



Columbia Oil #455 Oil Derrick
30-90244 \$89.95
Measures: 9 3/4" x 5 3/4" x 13 3/4"

#395 Floodlight Tower
30-11078 \$49.95
Measures: 5" x 5" x 11 1/4"

Tippy's Tacos - Fast Food Restaurant Stand
30-90085 \$59.95
Measures: 14 1/2" x 12" x 7 1/2"

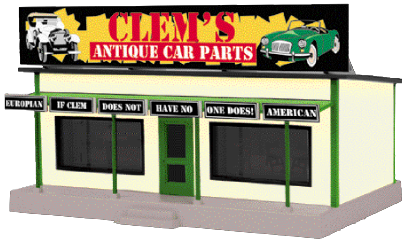
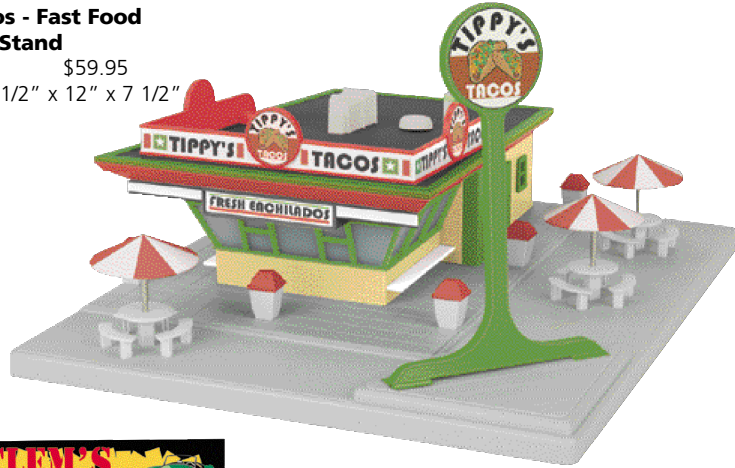

Clem's Antique Car Parts Road Side Stand
30-90234 \$39.95
Measures: 8 1/2" x 5 7/16" x 4 1/4"

Mike's Model Trains - Road Side Stand
30-90235 \$39.95
Measures: 8 1/2" x 5 7/16" x 4 1/4"



Gray & White - Public Works Building
30-90007 \$79.95
Measures: 14 1/8" x 9 7/8" x 8 1/8"

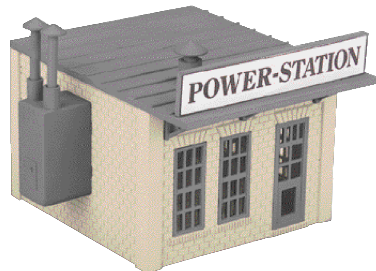

Cream & Dark Gray - Power Station
30-90003 \$29.95
Measures: 4 1/4" x 4 1/8" x 3 7/8"



RailTown City Bank - Bank w/Coin Slot
30-90223 \$59.95
Measures: 9 1/2" x 17 15/16" x 9 1/8"



Main Street Hardware - Single Story Opposite Corner Store
30-90218 \$49.95
Measures: 10 3/8" x 8 3/8" x 6 1/4"

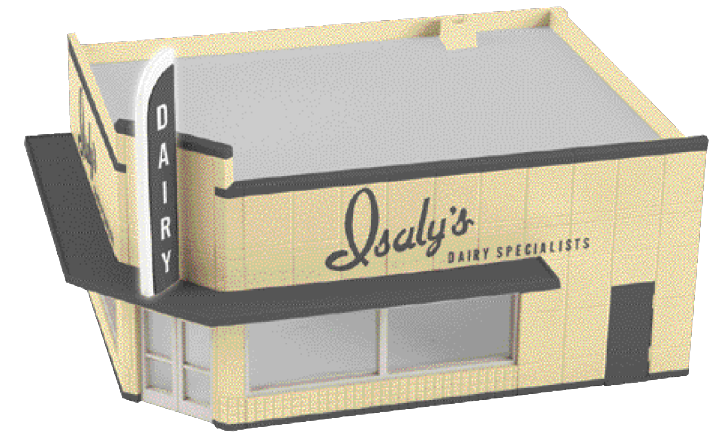

Isaly's Dairy - Single Story Corner Store
30-90215 \$49.95
Measures: 10 3/8" x 8 3/8" x 6 1/4"

BUILDINGS HAVE OPERATING INTERIOR LIGHTING



Zang's Hotel - 2-Story Hotel Building
30-90162 \$39.95
Unit Measures: 6 1/2" x 8" x 8 5/8"

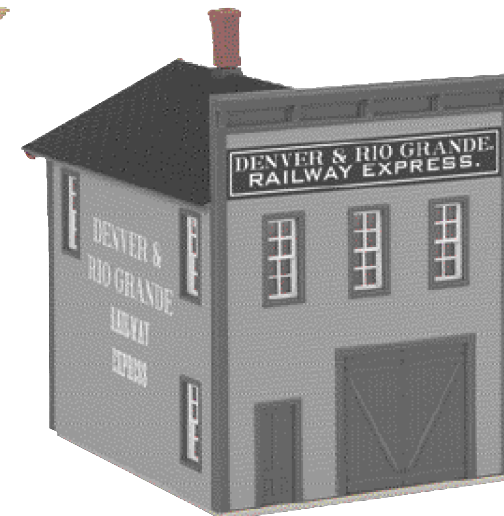

D&RG Railway Express - 2-Story Livery Building
30-90163 \$39.95
Measures: 6 1/2" x 8" x 7 3/4"

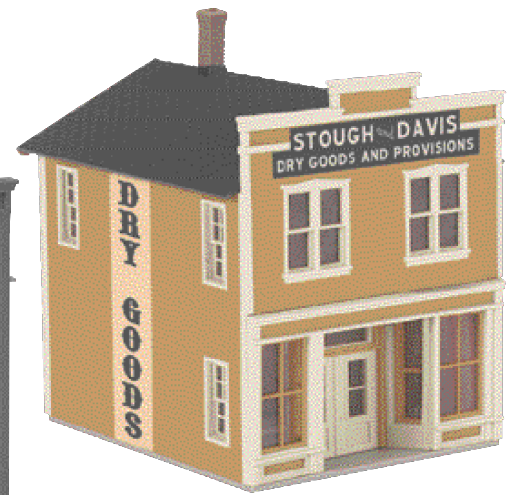

S&D Dry Goods and Provisions 2-Story Store Front Building
30-90164 \$39.95
Measures: 6 1/2" x 8" x 8 5/8"



Cosmo Family Pizzeria - Single Story Opposite Corner Store
30-90217 \$49.95
Measures: 10 3/8" x 8 3/8" x 6 1/4"



Ted's Tires - Single Story Corner Store
30-90216 \$49.95
Measures: 10 3/8" x 8 3/8" x 6 1/4"

Accessories



Anita Mann Dating Service - Opposite Corner Building w/Blinking Sign
30-90233 \$49.95
Measures: 9 7/8" x 7 7/16" x 7 1/16"

INCLUDES
BLINKING STORE
WINDOW SIGN



Owen Cash Pawn Shop - Opposite Corner Building w/Blinking Sign
30-90232 \$49.95
Measures: 9 7/8" x 7 7/16" x 7 1/16"



Renee's Packaged Goods Liquor Store - 3-Story City Building
30-90225 \$39.95
Measures: 6 5/8" x 9 1/2" x 8 3/4"



Grubba & Co. Paper Shredders 3-Story City Building
30-90224 \$39.95
Measures: 6 5/8" x 9 1/2" x 8 3/4"



Dewey, Cheetum & Howe - 3-Story City Building w/Fire Escape & Blinking Sign
30-90154 \$59.95
Measures: 12 3/4" x 6 5/16" x 9 3/16"



Bowhunter's Corner - Corner Building w/Blinking Sign
30-90173 \$49.95
Measures: 9 7/8" x 7 7/16" x 7 1/16"

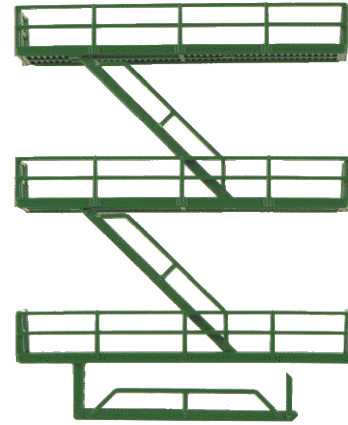

3 Piece Building Fire Escape Set - Green
30-90258 \$14.95
Measures: 5 1/2" Wide

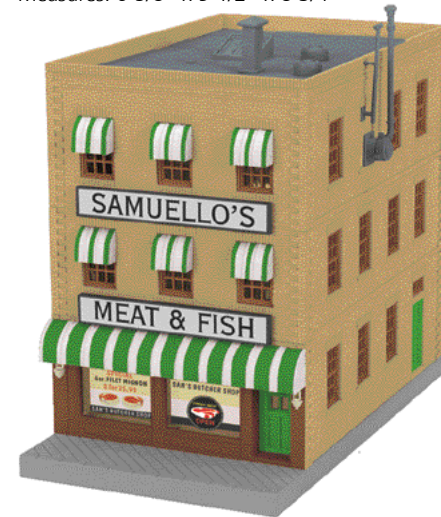

Sam's Butcher Shop - 3-Story City Building w/Fire Escape & Blinking Sign
30-90227 \$59.95
Measures: 12 3/4" x 6 5/16" x 9 3/16"



O'Mara's Irish Brewing Company 3-Story City Building w/Fire Escape & Blinking Sign
30-90052 \$59.95
Measures: 12 3/4" x 6 5/16" x 9 3/16"



Maple Donuts - 3-Story City Building w/Fire Escape & Blinking Sign
30-90226 \$59.95
Measures: 12 3/4" x 6 5/16" x 9 3/16"



Ilene Wright Chiropractic - Corner Building w/Blinking Sign
30-90231 \$49.95
Measures: 9 7/8" x 7 7/16" x 7 1/16"



Ben Dover Proctologist - Corner Building w/Blinking Sign
30-90230 \$49.95
Measures: 9 7/8" x 7 7/16" x 7 1/16"



M.T.H. Train Store - 3-Story City Building w/Blinking Sign
30-90049 \$59.95
Measures: 12 3/4" x 6 5/16" x 9"

EXPAND THE ABOVE BUILDINGS WITH ADD-ON ADDITIONS

O'Mara's Irish Pub - City Building w/Fire Escape Single Story Addition
30-90197 \$24.95
Measures: 12 3/4" x 6 5/16" x 2 1/2"

Accessories

BUILDINGS HAVE
**OPERATING
INTERIOR LIGHTING**



Neil's New & Used Guitars - 4-Story Building
30-90229 \$49.95
Measures: 10 7/8" x 8 5/8" x 8 7/8"



Jerry's Comics (Buy, Sell, Trade) - 4-Story Building
30-90228 \$49.95
Measures: 10 7/8" x 8 5/8" x 8 7/8"



The Brunswick - 6-Story Building
30-90016 \$69.95
Measures: 8 7/8" x 8 5/8" x 15 5/8"



Frederick Avenue - 5-Story Hotel w/Blinking Sign
30-90237 \$69.95
Measures: 12 3/4" X 6 5/16" X 13 1/2"

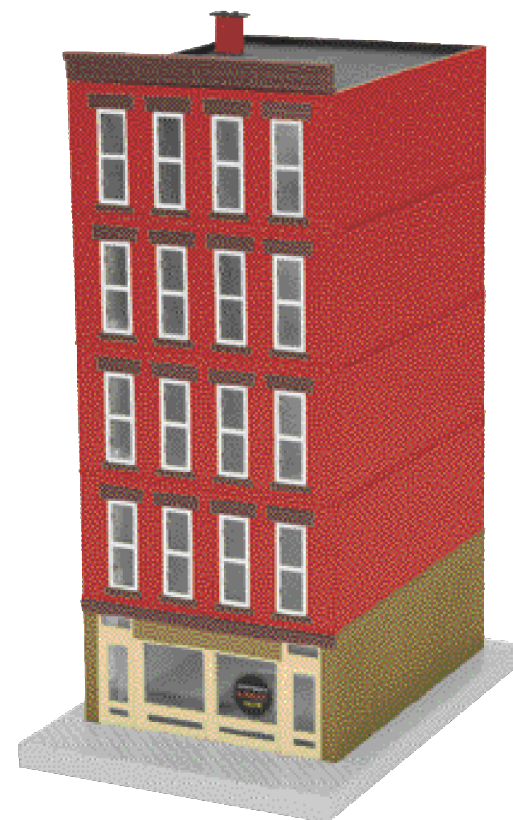

Main Street - 5-Story Hotel w/Blinking Sign
30-90236 \$69.95
Measures: 12 3/4" X 6 5/16" X 13 1/2"

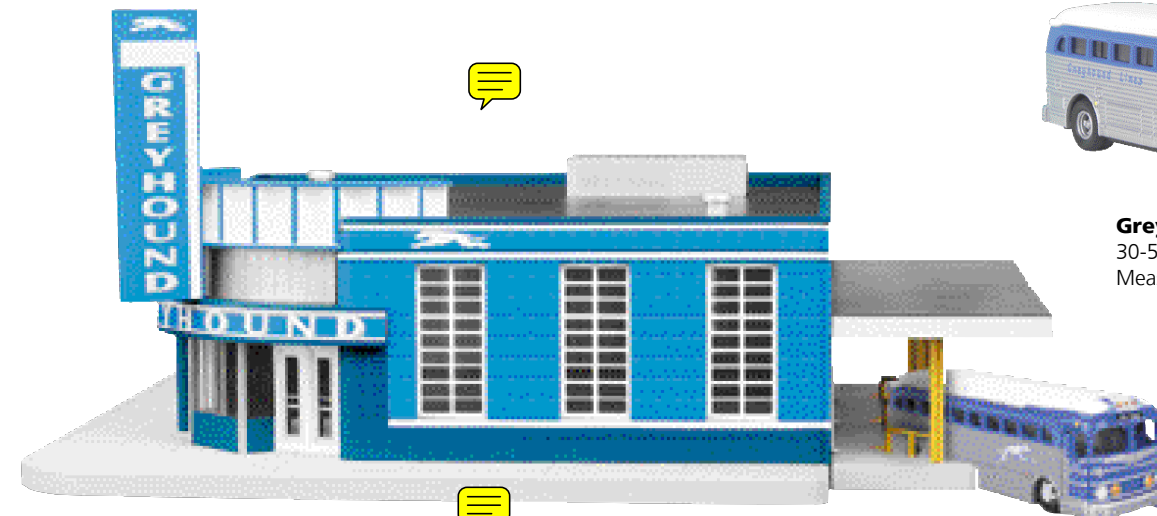

Greyhound - Bus Station
30-9040 \$129.95
Measures: 16 1/2" x 18 3/4" x 9 1/2"



Greyhound® - Die-Cast Bus
30-50017 \$29.95
Measures: 8" x 1 15/16" x 2 1/8"

Columbia Oil - Tank Filling Station
30-90099 \$49.95
Measures: 16 1/8" x 5" x 8 1/8"



RailTown Signature Series



**SOOT-COVERED
WALKWAY**

Watch as walkway
lowers to fill tank
car!

Tank lid lowers
and raises as
tank is "filled
or drained".



**DIRTY STEPS &
STAINED INNER
TANK WALLS**

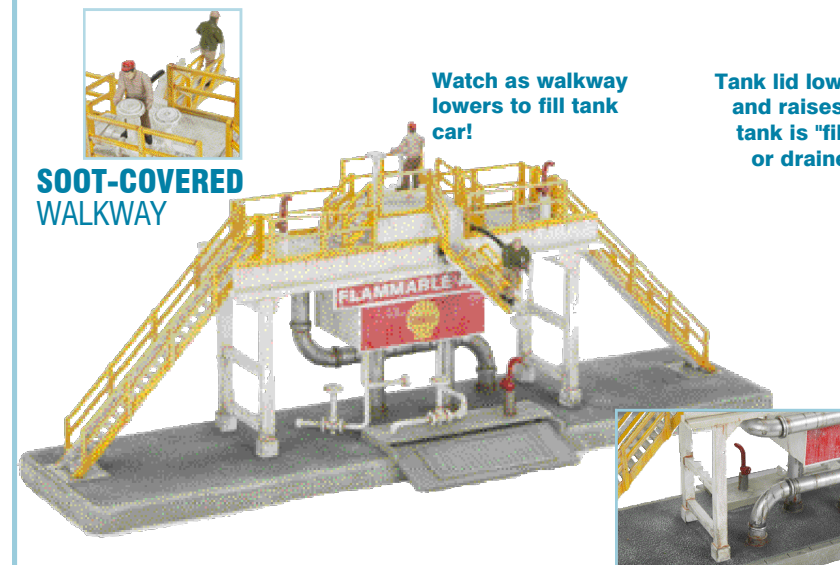

Shell - Weathered Operating Storage Tank Station
30-9150 \$199.95
Measures: 16 1/8" x 5" x 8 1/8"

**GRIMY
CEMENT BASE**



Shell - Weathered Operating Storage Tank
30-9149 \$199.95
Measures: 17 5/16" x 11" x 10"

SEE THEM IN ACTION
VISIT WWW.MTHTRAINS.COM

MTH RailRoders Club™

JOIN THE CLUB

There are SIX different types of memberships, based on the style of model railroading that most interests you.

JOIN ONLINE! IT'S EASY - JUST GO TO WWW.MTHTRAINS.COM

RailKing Membership



30-73235 2007 MTHRC Wooden Tank Car
RailKing Membership is \$50.00

Premier Membership

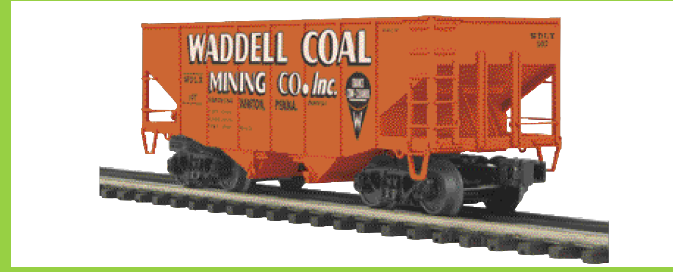

20-97200 2007 Waddell Coal 2-Bay Fish Belly Hopper
Premier Membership is \$50.00

Standard Gauge Tinplate Membership 200 Series



10-2223 2007 MTHRC 200 Series Reefer Car
Tinplate 200 Series Membership is \$120.00

O Gauge Tinplate Membership 2800 Series



10-8069 2007 MTHRC 2800 Series O Gauge Tank Car
Tinplate 2800 Series Membership is \$80.00

One-Gauge Membership



70-75020 N&W 4-Bay Hopper Car
One-Gauge Membership is \$100.00

Basic Club Membership

60-1000 - The Basic Club Membership does not include a club car
Basic Membership is \$25.00



AS A MEMBER OF THE M.T.H. RAILROADERS CLUB YOU'LL RECEIVE:

Limited-Edition Club Car



Each year we produce beautifully decorated cars exclusively for our Club members. Members automatically receive the car that matches their Club membership (RailKing®, Premier, Tinplate Traditions™ or One Gauge) & have the option to collect the other Club cars as well.

RailWare™ Software CD-ROM

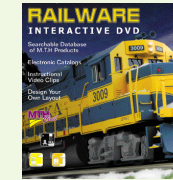

Use your computer to design track layouts, search the database of all M.T.H. products, look at our past catalogs, listen to Proto-Sound® 2.0 train effects, & much more. This CD retails for \$79.95, but is yours FREE as a Club member.

The CrossingGate™ Club Magazine



You will receive our full color Club magazines, jam-packed with product news, ideas from other members, rail history, & step-by-step articles explaining how M.T.H. technology can bring your railroad to life.

Club Card & Lapel Pin



Show the world your membership in this elite group of model railroaders with your high-quality embossed membership card & beautiful enamel lapel pin.

1st Class Mailing of M.T.H. Catalogs



Club Members get all of our catalogs earlier than all our other mailing list members via First-Class mailings, so they can order from their local train store before the best items are sold out.

Proto-Sound® 2.0 Upgrade Kits

Club members can save an additional 15% on these kits by visiting the MTHRC web page.

Club Web Site

Visit WWW.MTHTRAINS.COM & type in your member number to gain access to the Club web site. Here you can exchange messages with other Club members, keep up with the latest news, & even build your own homepage.

CARRY ON THE M.T.H. TRADITION WITH MEMORABILIA AND COLLECTIBLES

MTH Promotional DVD

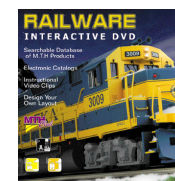

This interactive DVD is packed full of sights & sounds guaranteed to make you rethink how far the hobby of model railroading has come. You'll learn about some of the most innovative products ever produced & marvel at the sophistication of a product line unmatched by other model train manufacturers.



Previous Year Club Cars

MTHRC members can still obtain earlier produced MTHRC cars by visiting the MTHRC pages on the website. Only MTHRC members can get these cars!

A Toy Train Story

This comprehensive book is a must for collectors & other lovers of toy trains. 350 pages & 1900 color photos, hard cover. Add this book to your membership for only \$25.00 (50% off the \$49.95 cover price)!



GET THE MOST FROM MODEL RAILROADING

DCS™

...SIMPLY

THE **BEST WAY** TO

RUN A RAILROAD



TRY IT AT YOUR LOCAL
DCS DEMO CENTER
OR LEARN MORE WITH A
COMPLIMENTARY DVD
ON DCS AND M.T.H. TECHNOLOGY



Take your favorite Proto-Sound® 2.0 locomotive to any demo center and experience the additional features your engine has with DCS™ control.

TO FIND YOUR NEAREST DCS DEMO CENTER
OR REQUEST YOUR COMPLIMENTARY DVD VISIT

WWW.MTHTRAINS.COM

